

State Cinematographic Committee of USSR



Scientific production association “EKTRAN”  
Factory “Moskinap”

High-speed light-weight cine camera  
“TEMP” 1SKL-M

Technical description and user manual



Translated by Rafael Pankratau  
Edited by Terry Byrne

## Table of content

1. INTRODUCTION.....	- 4 -
2. PURPOSE.....	- 4 -
3. TECHNICAL SPECIFICATIONS .....	- 5 -
4. LIST OF PARTS INCLUDED INTO DELIVERY SET. ....	- 7 -
4.1. Standard delivery set.....	- 7 -
4.2. Additional parts available by special order. ....	- 8 -
5. CONSTRUCTION OF THE CAMERA AND ITS OPERATION .....	- 9 -
5.1. Operation principles.....	- 9 -
5.2. Construction of the camera. ....	- 9 -
5.3. Kinematic diagram. ....	- 10 -
5.4. Optical diagrams.....	- 12 -
5.5. Electrical diagrams.....	- 13 -
6. CONSTRUCTION AND OPEARION OF THE MAIN COMPONENTS OF THE CAMERA.....	- 21 -
6.1. The camera body.....	- 21 -
6.2. Construction of the camera.....	- 22 -
6.3. The aperture change mechanism for zoom lens 35OPF15-1A. ....	- 24 -
6.4. The aperture change mechanism for 200mm and 300mm lenses. ....	- 25 -
6.5. A 120m mag. ....	- 26 -
6.6. A 300m mag. ....	- 27 -
6.7. The shooting speed knob.....	- 28 -
6.8. Viewfinder.....	- 29 -
6.9. Lenses in focusing mounts. ....	- 30 -
6.10. The heavy lens support.....	- 30 -
6.11. The FPS indicator (tachometer). ....	- 30 -
6.12. The power source. ....	- 30 -
6.13. Electrical heating unit.....	- 31 -
6.14. A shoulder support.....	- 33 -
6.15. The heaters for the camera and for the power source.....	- 34 -
6.16. Film gates with shifted frame window “HC”, “AC”. ....	- 34 -
6.17. Transport case.....	- 34 -
7. MARKING AND PACKING.....	- 35 -
8. GENERAL OPERATING INSTRUCTIONS .....	- 35 -
9. SAFETY MEASURES .....	- 35 -
10. PREPARATION FOR WORK.....	- 36 -
10.1. Loading a mag. ....	- 36 -
10.2. Loading the camera. ....	- 36 -
10.3. Mounting of light protecting devices. ....	- 37 -
10.4. Mounting of the aperture change mechanism onto 35OPF15-1A zoom lens. ....	- 37 -
10.5. Mounting of the aperture change mechanism for 200mm and 300mm lenses.....	- 37 -
10.6. Mounting the camera onto a tripod. ....	- 38 -
10.7. Preparation of the 35OPF15-1 lens for anamorphic shots.....	- 38 -
10.8. Mounting of the heating unit. ....	- 39 -
11. CONTROLLING THE CAMERA .....	- 40 -
11.1. Start and stop. ....	- 40 -
11.2. Setting shooting speed.....	- 40 -
12. TROUBLESHOOTING .....	- 41 -
13. EFFORTS AND PERIODICITY OF MAINTENANCE INSPECTIONS.....	- 42 -
13.1. Cleaning of the camera and mags. ....	- 42 -
13.2. Cleaning of optics. ....	- 42 -
13.3. Cleaning of the mirror shutter.....	- 42 -
13.4. Lubricating.....	- 42 -
14. DISASSEMBLING AND ASSEMBLING OF THE CAMERA.....	- 43 -
15. CONSERVATION.....	- 43 -

## List of pictures

Picture 1. General view. ....	- 9 -
Picture 2. Kinematic diagram. ....	- 11 -
Picture 3. Optical diagram with the normal viewfinder. ....	- 12 -
Picture 4. Optical diagram with the deanamorphic viewfinder. ....	- 13 -
Picture 5. Electrical diagram of the camera with a power source. ....	- 15 -
Picture 6. Electrical diagram of the mechanism to change shooting speeds and apertures. ....	- 16 -
Picture 7. Electrical diagram of a 300m mag. ....	- 17 -
Picture 8. Electrical diagram of connections between the camera and a 300m mag. ....	- 17 -
Picture 9. Electrical diagram of the thermal control unit. ....	- 18 -
Picture 10. Electrical diagram of the camera heating jacket. ....	- 19 -
Picture 11. Electrical diagram of the power source heating jacket. ....	- 19 -
Picture 12. Electrical diagram of connection the camera with the heating units. ....	- 20 -
Picture 13. The camera with the door opened. ....	- 21 -
Picture 14. The camera with a 300mm lens and support for heavy lenses. ....	- 22 -
Picture 15. The shutter mechanism. ....	- 23 -
Picture 16. The intermittent movement mechanism. ....	- 24 -
Picture 17. The aperture change mechanism for the 35OPF15-1A lens. ....	- 25 -
Picture 18. The aperture change mechanism with a 300mm lens. ....	- 26 -
Picture 19. A 120m mag. ....	- 27 -
Picture 20. A 300m mag with removed lid. ....	- 28 -
Picture 21. The camera with a 75mm lens. ....	- 29 -
Picture 22. Viewfinder with interchangeable eyepiece elbow for normal and wide-screen shots. ....	- 29 -
Picture 23. The heavy lens support (for 200mm and 300mm lenses). ....	- 30 -
Picture 24. The power source. ....	- 31 -
Picture 25. Electrical heating unit. ....	- 32 -
Picture 26. The shoulder support. ....	- 33 -
Picture 27. Loading the camera. ....	- 37 -
Picture 28. The 300mm lens with the aperture change mechanism and the heavy lens support. ....	- 38 -

## **1. INTRODUCTION**

This is a technical description and user manual for the high-speed light-weight cine camera "Temp" 1SKL-M, and contains complete information necessary for the use of technical functions of this camera and its correct operation.

## **2. PURPOSE**

This camera is designed for shooting hand-held or from a light tripod. It can be used to film documentaries, popular science films, feature movies and other standard and wide-screen movies on black-and-white or color 35mm film.

### 3. TECHNICAL SPECIFICATIONS

Film	35mm, GOST 4896-73
Size and position of the image on the film	GOST 13679-68
Position and movement of the film in the camera	Single plane, forward direction only
Magazine capacity, meters	120, 300
Shooting frequencies, FPS	Sync at 24, variable from 24 to 150
Stability of the fps through whole film reel at maximum mag load, %, not more than	
at sync 24 fps	±2.5
at variable 24-150 FPS	±8
Image instability, mm, not more than	
below 72 FPS	0.02±0.01
above 72 FPS	0.03±0.01
Shutter	Single blade mirror placed in side position at 45°, with fixed 150° opening
Pulldown mechanism	Two sides, two teeth per side
Registration mechanism	Two sides, two teeth per side
Viewfinders:	
standard	6x magnification
deanamorphic	7x horizontal magnification 3.5x vertical magnification
Available lenses:	
primes	18, 22, 28, 35, 50, 75, 100, 150, 200, 300mm. Zoom lens 35OPF15-1A without attachment
anamorphics	Anamorphic lenses 35A, 50A, 75A, zoom lens 35OPF15-1A (50-500mm)
Focusing method	By the ground glass image from the mirror shutter with aid of the viewfinder; by lenses' distance scales.
Diaphragm scales	In range of effective speeds
Method of providing of consistent exposures	By the mechanism of aperture change in transition mode
Change of optical density of different areas of the frame in transition mode, not more than	0.05
Time to reach 150 FPS from a start, in seconds, not more than	3
Camera drive	DC motor with speed transducer
Power voltage, V	27(+5/-3)
Peak power consumption, A	20
Tripod nut	3/8"

#### Operation conditions.

Environment temperature, °C	-20 to +40
with electrical heater	from -30
Relative humidity, %	95 at temperature up to 20°C
Noise level, dBA (without heater bag):	
at 150 FPS	88
at 24 FPS	68
Dimensions of the camera with the zoom lens 35OPF15-1A, 120m mag, matte box and	

standard viewfinder mounted on it, mm, not more than	
length	805
width	301.5
height	301.5
Weight of the camera with 50mm lens, 120mm mag (empty) and matte box (without FPS indicator), kg, not more than	12

## 4. LIST OF PARTS INCLUDED INTO DELIVERY SET.

### 4.1. Standard delivery set.

Table 1

Name	Quantity		Notes
	Standard version	Wide-screen version	
1. Camera "Temp" 1SKL-M with following parts:	1	1	
- normal film gate	1	1	
- FPS handle	1	1	
- lens mount cap	1	1	
- viewfinder mount cap	1	1	
2. Taking 18mm lens in a focusing mount	1	1	OKS5-18-1
3. Taking 22mm lens in a focusing mount	1	1	OKS3-22-1
4. Taking 28mm lens in a focusing mount	1	1	OKS7-28-1
5. Taking 35mm lens in a focusing mount	1	1	OKS11-35-1
6. Taking 50mm lens in a focusing mount	1	1	OKS1-50-6
7. Taking 75mm lens in a focusing mount	1	1	OKS6-75-1
8. Taking 100mm lens in a focusing mount	1	1	OKS2-100-2
9. Taking 150mm lens in a focusing mount	1	1	OKS1-150-1
10. Taking 200mm lens in a focusing mount	1	1	OKS1-200-1
11. Taking 300mm lens in a focusing mount	1	1	OKS1-300-1
12. 35mm anamorphic lens	–	1	35BAS27-1, in its own package
13. 50mm anamorphic lens	–	1	35BAS22-2, in its own package
14. 75 mm anamorphic lens	–	1	35BAS23-2, in its own package
15. 120m mag	1	1	
16. 300m mag	1	1	
17. Normal viewfinder	1	1	
18. Deanamorphic viewfinder	–	1	
19. Wide-screen film gate	1	1	
20. Heavy lens support	1	1	
21. Matte box	1	1	For 18-75mm lenses
22. Matte box	–	1	For anamorphic 35, 50, 75mm lenses
23. Diaphragm mechanism	1	1	For 200, 300mm lenses
24. Control unit	1 set	1 set	
25. Battery block SCS-5	1 set	1 set	
26. Battery block SCS-15	1 set	1 set	
27. Cable	1	1	1.2m
28. Cable	1	1	3m
29. Handle	1	1	
30. Mag port cover	1	1	
31. Lens hood	1	1	For 35mm lens
32. Lens hood	1	1	For 50mm lens

33. Lens hood	1	1	For 75mm lens
34. Lens hood	1	1	For 100mm lens
35. Lens hood	1	1	For 150mm lens
36. Lens hood	1	1	For 200mm lens
37. Lens hood	1	1	For 300mm lens
38. Attachment	1	1	For 300mm lens
39. Adapter	1	1	
40. Shoulder support	1	1	
41. Carrying case #1	1	1	For the camera
42. Carrying case #2	1	1	For mags
43. Carrying case #3	1	1	For power sources
44. Carrying case #4	1	1	For accessories
45. Carrying case #5	–	1	For anamorphic optics
46. Soft cover	1	1	For a power source
47. Support	–	1	
Documents			
48. Technical description and user manual	1	1	
49. Logbook	1	1	

**4.2. Additional parts available by special order.**

Table 2

Name	Quantity	Notes
1. Zoom lens 50-500mm	1	35OPF15-1A, with linear diaphragm scale
2. Aperture change mechanism	1	For 35OPF15-1A lens
3. Matte box	1	For 35OPF15-1A lens
4. Bracket	1	For 35OPF15-1A lens
5. Normal film gate with shifted frame position “HC”; 6. Wide-screen film gate with shifted frame position “AC”	1	For effect of reversal movement
7. Electrical heater	1	
8. Carrying case #6	1	For a power source and soft cases
9. Soft case	1	For the heater
10. Soft case	1	Without adapter

## 5. CONSTRUCTION OF THE CAMERA AND ITS OPERATION

### 5.1. *Operation principles.*

Operating principles of the camera are based on photographing of movement on film by means of intermittent film motion.

Main parts of the camera (camera body, batteries, control unit) are connected to each other with electrical cables.

### 5.2. *Construction of the camera.*

General view of the camera is shown in the Picture 1.

The camera consists of the following main parts:

- camera includes a body, a body door, mirror shutter mechanism, intermittent movement mechanism, film transport mechanism;
- mechanism of aperture change for a 35OPF15-1A lens;
- mechanism of aperture change for 200mm and 300mm lenses;
- 120m mag;
- 300m mag;
- shooting speed handle;
- viewfinder;
- lenses in focusing mounts;
- FPS indicator;
- power source;
- electrical heater unit;
- shoulder support;
- set of cables.



Picture 1. General view.

### **5.3. Kinematic diagram.**

Kinematic diagram is shown in Picture 2. It consists of the camera kinematic diagram, aperture change mechanism, and a mag.

#### **5.3.1. Camera kinematic diagram.**

It is shown in Picture 2. It works as follows.

Motor (1) connected in alignment with the axle (I) of the speed transducer (2) transmits its rotation to the main axle (II) through play-free couplers (3) and pair of cone gears (4,5). Axle (II) transmits rotation to the axle (III) of the shutter (6) through cone gears (7,8); to the axle (IV) of the film transport 32-teeth sprocket (11) through the pair of helical gears (9,10); and to the axle (V) through the pair of helical gears (10,12). Take-up lug (13) of a mag actuates by the axle (V) through the block of cog wheels (14,15,16) from the axle (IV), and through the cog wheel (17). The last cog wheel couples with cog wheel (18) of the installed mag.

Evenly rotating 32-teeth sprocket takes film from the feeding spool (19) and feeds it into the film channel forming a loose loop.

Intermittent film motion is provided by a crank type intermittent movement mechanism with a pair of double-toothed pulldown claws.

Registration of the film during exposure is provided by a pair of double-toothed registration pins. Then, the film is fed to another 32-teeth sprocket and further to the take-up spool (13).

#### **5.3.2. Kinematic diagram of the aperture change mechanism.**

Kinematic diagram of the aperture change mechanism for 200mm and 300mm lens is shown in Picture 2.

It provides connection of the non-linear diaphragm scale with a potentiometer axle which changes shooting speed by means of interchangeable adjusting tappets.

This works as described below.

Turning the handle (25) clockwise you smoothly change shooting speed from 24 to 150 FPS. In the same time, the aperture of the installed 200mm or 300mm lens changes.

Movement of the control handle transmits to the 200mm or 300mm lens aperture scale through pair of cylindrical helical gears (26,27) and spurs (28,29).

Interchangeable tappets (30) are placed on the axle of the control handle. They convert non-linear movement of lens aperture scales into linear motion.

Roller (31) (8mm diameter) placed on a lever is pressed to the tappet. Maximum angle of the lever lift is 30°. Kinematic chain from the tappet to the potentiometer (32) contains calculator (33) of the aperture value according to the frame rate. Movement of the tappet is transmitted to the calculator and to the potentiometer by means of this lever.

There is a helical spring (34) on the potentiometer axle that provides a play-free reverse motion of the potentiometer. The potentiometer is connected to the aperture change mechanism through the play-free coupling (35). Torsion torque of the spring provides pressure of the roller to the work surface of the tappet.

#### **5.3.3. Kinematic diagram of the 300m mag.**

Kinematic diagram of the 300m mag is shown in Picture 2.

Each mag has its own motor (41) with worm-and-wheel gearbox that has a 1:18 ratio.

Input axle of the reducer is connected to the take-up spool of the mag through the friction coupling (43) and an overrunning clutch.

Kinematic diagram of the 120m mag is the same. Rotation speed of the mag motor and reducer ratio are set so that they start to work by means of the overrunning clutch (42) when rotation speed of the take-up spool (13) corresponds to a 70m film roll.

While there is less than 70m of the film on the take-up spool, it is powered by the main camera motor. The mag motor rotates at slower speed than the take-up spool, and overrun by the overrunning clutch. When rotation speed of the take-up spool becomes slower than speed of the

mag motor (due to bigger film roll), the overrunning clutch stops, and the mag motor starts to help the camera motor to wind the film.

Start and stop of the mag motor are accomplished simultaneously with the camera motor by the same button.

The take-up spool has a friction mechanism preventing loose loops during film movement through the camera. A block brake installed on the feeding spool prevents unwinding of the film when camera stops. The block brake is released by an electromagnet at the moment of the camera start by "Start" button.

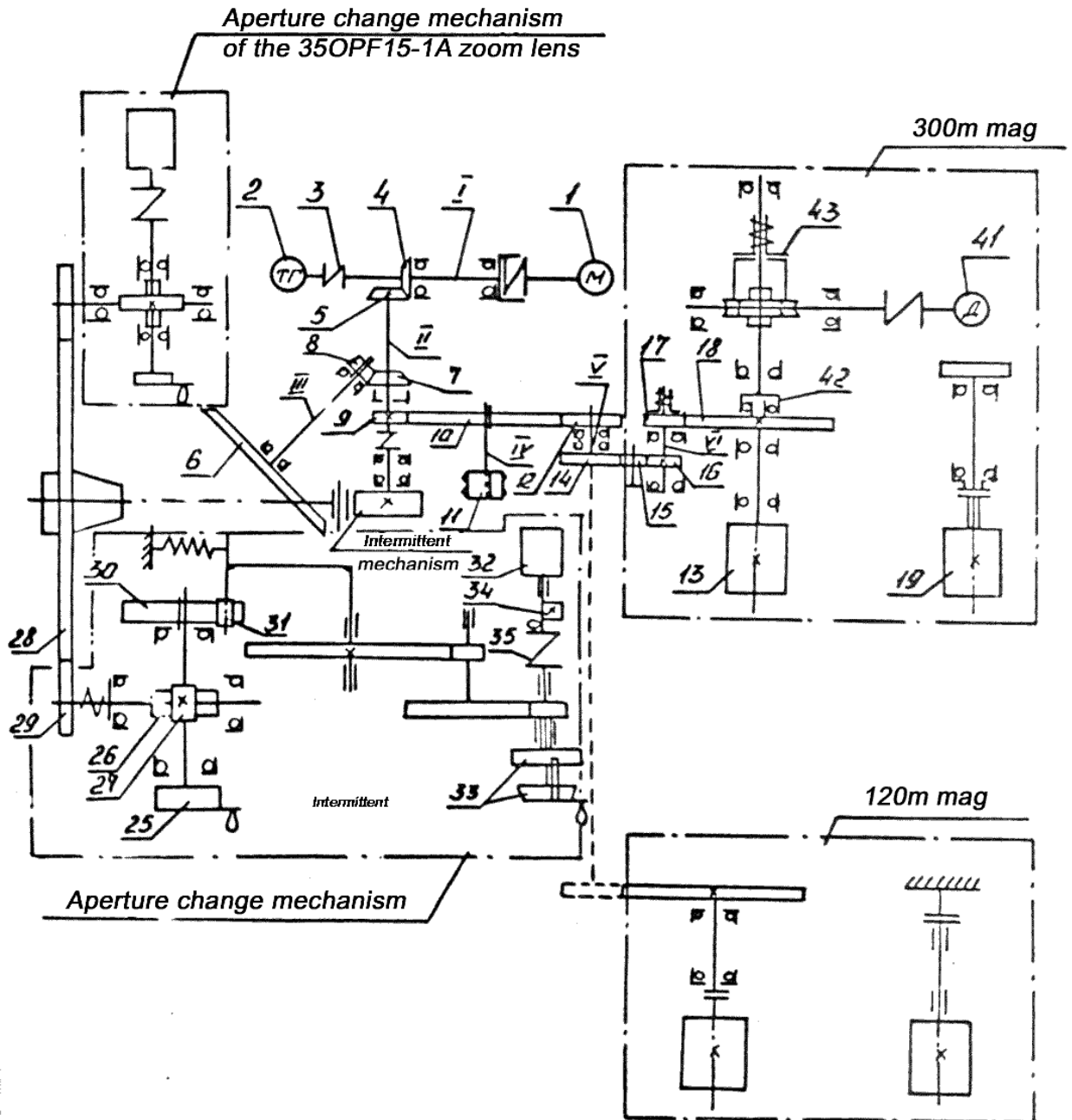

Picture 2. Kinematic diagram.

## 5.4. Optical diagrams.

### 5.4.1. Optical diagram with the normal viewfinder.

Optical diagram with the normal viewfinder is shown in Picture 3.

Taking lens (50) creates image of an object in the frame window of the film gate.

When the window is closed by the shutter (6), its mirror surface forwards the image onto the ground glass (51). Then the image goes through the shoe prism (52), the rectangular prism (53), lenses (54,55), and mirror (56) to the front focal plane of the viewfinder (57) with magnification of 0.6x. The viewfinder has 10x magnification, so resulting magnification is 6x.

The lenses (54,55) are set in such way that there is a beam of parallel rays between them.

Viewfinder can be turned to any angle around horizontal axis B-B for convenient use. This causes incline of the image. To compensate for this inclination, the prism (58) is set in the way of parallel rays between lenses (54) and (55). Rotating the prism (58) around horizontal axis B-B turns the image into correct position.

The miniature lamp (59) lights through the red filter (60), the rectangular diaphragm (61) and the prism (62). It gives a light signal in the field of view of the viewfinder (but beyond the frame limits) that indicates a limiting aperture value when the aperture change mechanism is used.

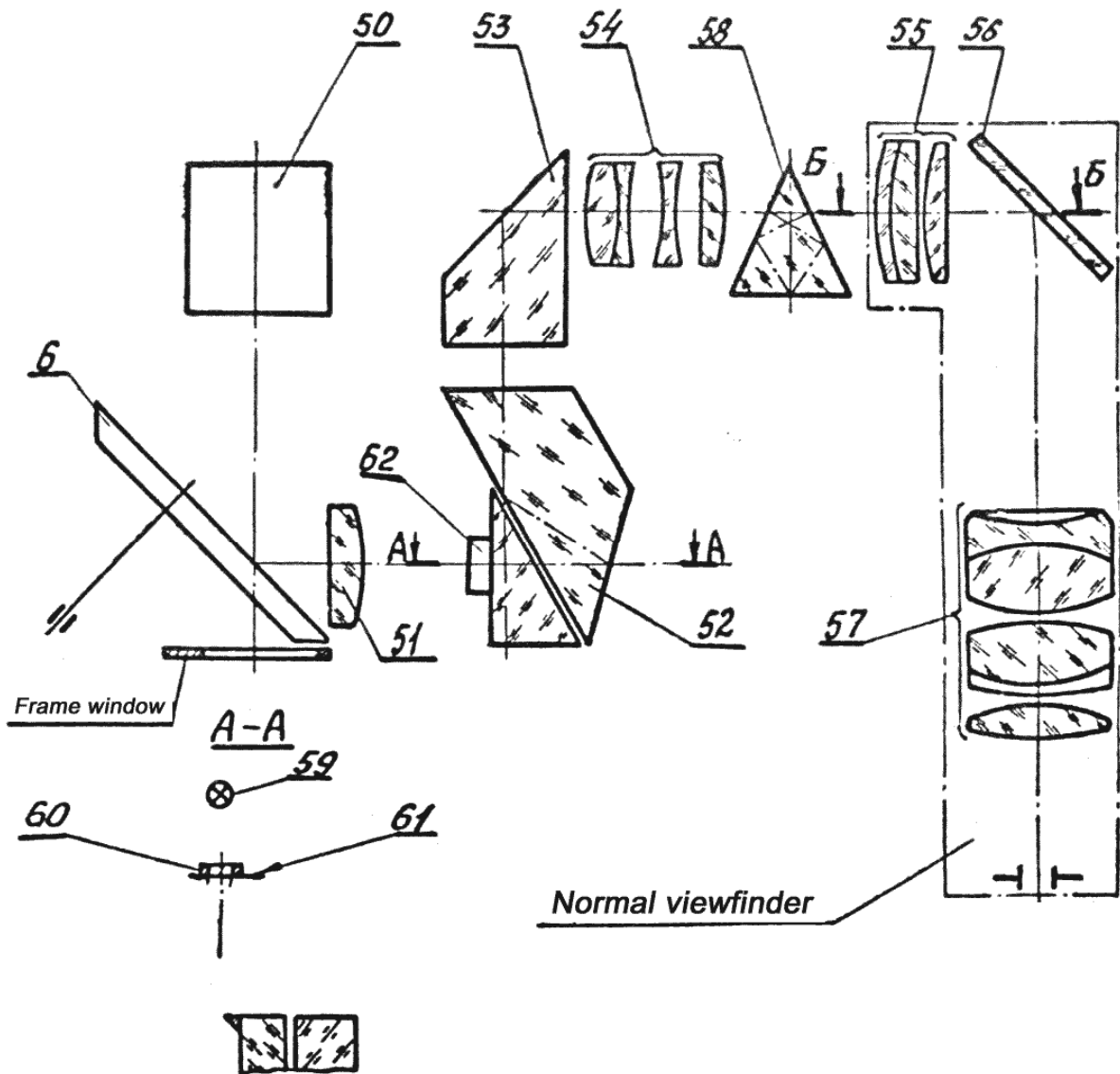

Picture 3. Optical diagram with the normal viewfinder.

### 5.4.2. Optical diagram with the deanamorphic viewfinder.

Optical diagram with the deanamorphic viewfinder is shown in Picture 4.

Taking lens (50) creates image of an object in the frame window of the film gate.

When the window is closed by the shutter (6), its mirror surface forwards the image onto the ground glass (66). Then the image goes through the shoe prism (52), the rectangular prism (53), lenses (54,67) (in a horizontal section), and the mirror (70) to the front focal plane of the viewfinder (69) with magnification of 0.35x. The viewfinder has 10x magnification, so resulting magnification is 3.5x (horizontal) and 7x (vertical).

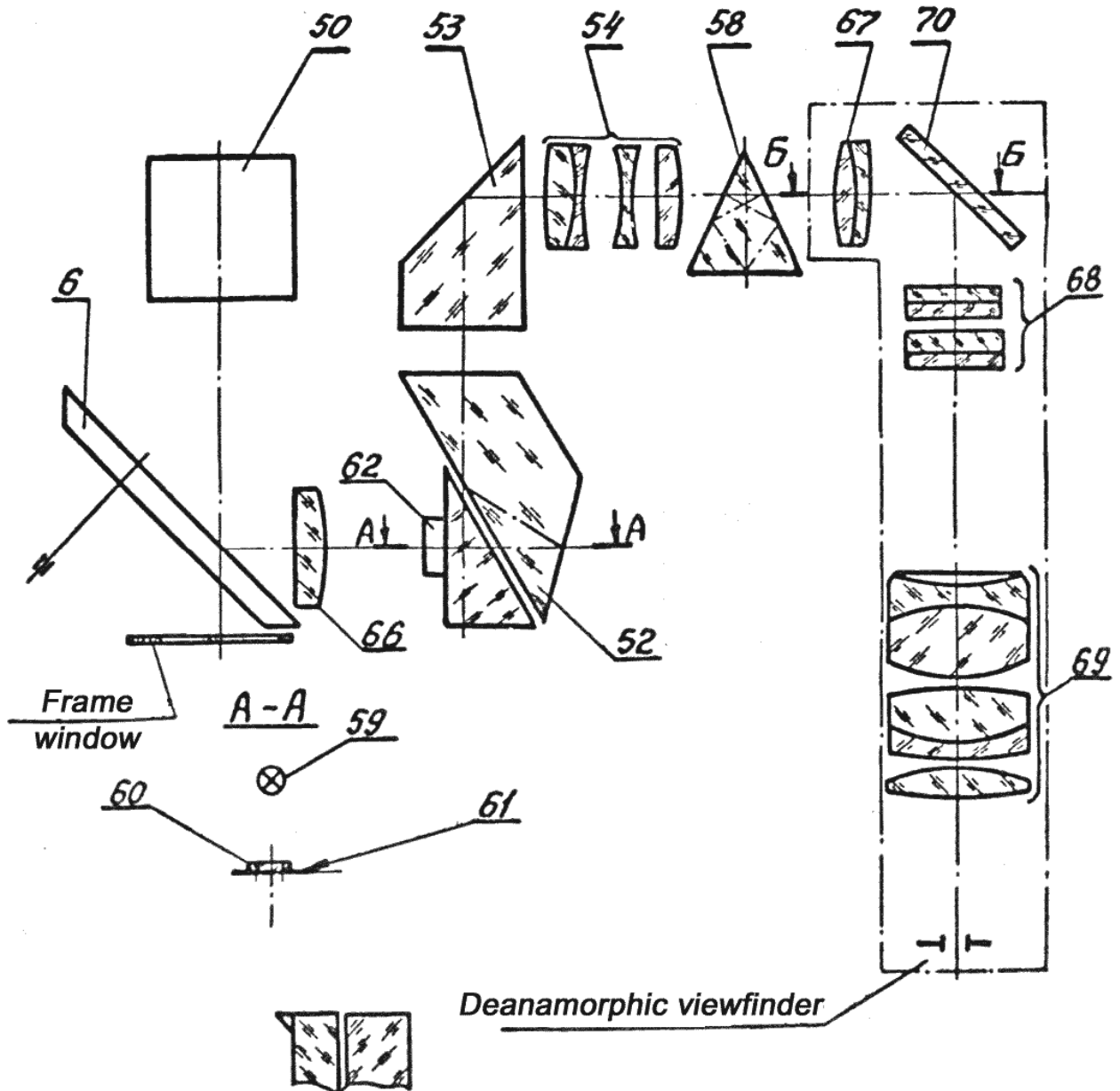

Picture 4. Optical diagram with the deanamorphic viewfinder.

### 5.5. Electrical diagrams.

Electrical diagrams are shown in Pictures 5-12. They contain diagrams of the following units: camera with a power source, mechanism of change of the shooting speeds and apertures, 300m mag, thermal control unit, heating soft cases.

### 5.5.1. Electrical diagram of the camera with a power source.

This diagram is shown in Picture 5.

The camera body contains the following main parts: the DC motor MU 332(M2), the speed transducer TGP-3 (M1), blocking micro switches (B2, B3), the “Start” button (B1), thermal contact (P2), the relay (P1) of the tachometer, and connectors Sh1-Sh7.

The connectors are used for the following units:

Sh1 – for the shooting speed and aperture change mechanism ;

Sh2 and Sh5 – internal connections;

Sh4 – for the power source cable;

Sh6 – for the main motor;

Sh7 – for any additional parts (tachometer, 300m mag, thermal control unit).

The power source consists of the two units firmly connected to each other – the control unit and the battery unit (containing 18 batteries SCS-15 or SCS-5).

The control unit has following controls: “Power” switch with “BKJI” (means “Switch ON”) engraved near it, “Mode” switch with “24” and “24-150” positions, and “Start” switch. It also has plugs for connecting the camera body, batteries, and a power monitor. Synchronization system works as described below.

Power from the batteries goes through the connector Sh1 and the switch B1 to the voltage stabilizer made of the transistor T1 and two diodes D1, D2. Stabilized 18V DC powers the preliminary amplifier made of the integral circuits U1, U2, and the parameter stabilizer made of the stabilitron D3. These units provide a highly stabilized reference voltage necessary to maintain steady shooting speeds.

To start the camera, set the B1 switch into “BKJI” position. Then either switch B2 switch “KAMEPA-IIYCK” into “IIYCK” position, or press corresponding button “IIYCK” on the camera. This will power the relay P1. Its contacts will power up a control circuit. The transistor T3 opens causing the transistor T4 to open too that switches ON a powerful output semiconductor switch made of transistors T5-T9. These transistors provides power to the camera motor M2, and it starts to run. Rotation of the motor transmits to the axle of the speed transducer (M1) included into feedback circuit to stabilize rotation speed of the motor. Output voltage of the speed transducer is in direct proportion to rotation speed of the motor. It is compared to the reference voltage. The difference of these two voltages is amplified by integral circuits U1, U2 and forward to the input of the amplifying cascade made of transistors T2, T3. If reference voltage is greater than the speed transducer voltage, then transistors T5-T9 of the output cascade are open, and power is supplied to the motor to increase its speed. When the speed transducer voltage reaches the value of the reference voltage, the amplifying cascade switches transistors T2 and T3 to a closed condition. This causes transistors T5-T9 to close too, and power is cut off from the motor. The motor slows down, and voltage of the speed transducer drops. When it drops below the reference voltage, all transistors open, and the whole stabilization process repeats.

It is possible to connect the FPS indicator (48) to monitor shooting speed. This indicator is a voltmeter with a scale marked in shooting speeds. The voltmeter readings correspond to the voltage of the speed transducer that is in direct proportion to the motor rotation speed.

The camera has the light-emitting diode (D1) to make a light mark on the film.

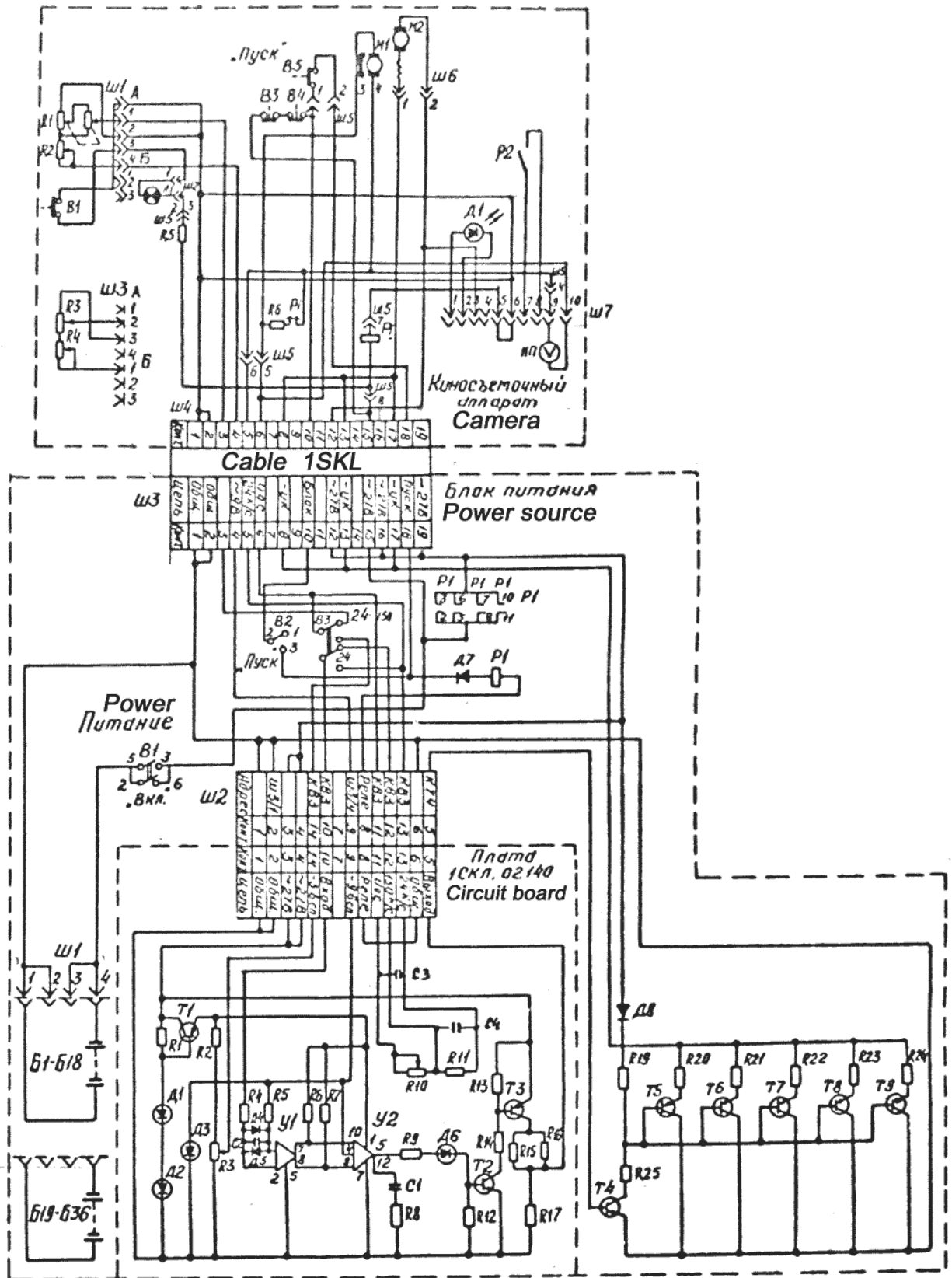

Picture 5. Electrical diagram of the camera with a power source.

Table 3 is omitted (it contains a list of the electrical components used in circuits of the camera and power source).

### 5.5.2. Electrical diagram of the mechanism of change shooting speeds and apertures.

This diagram is shown in Picture 6.

This unit consists of the potentiometer with a geared ring on its axle to provide a mechanical connection with the lens diaphragm ring. Electrical connection of the change mechanism with the control unit is done by the connector Sh2 through the camera.

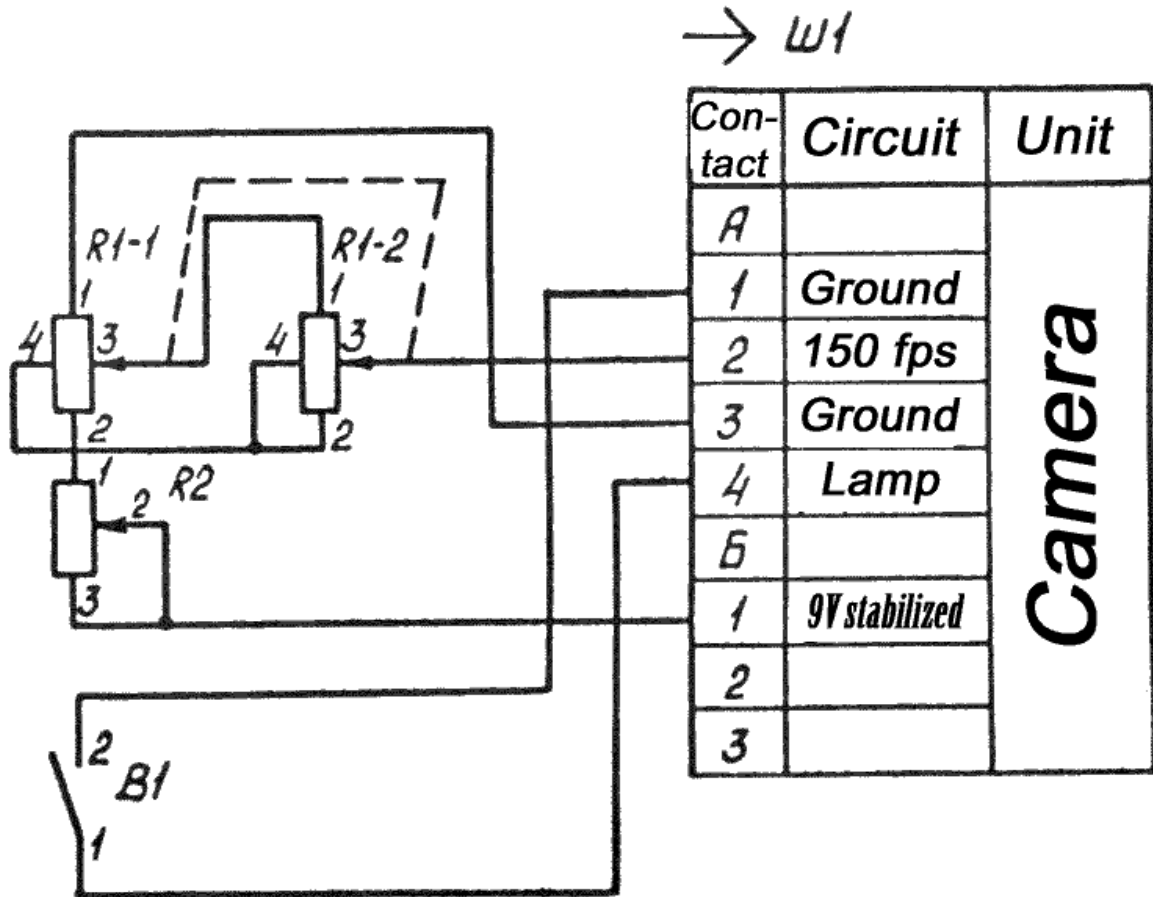

Picture 6. Electrical diagram of the mechanism to change shooting speeds and apertures.

Table 4 is omitted. It contains list of electrical components of the mechanism to change shooting speeds and apertures.

### 5.5.3. Electrical diagram of a 300m mag.

This diagram is shown at the Picture 6.

The mag has the tensioning motor DPM and following connectors:

Sh1 – to power the motor;

Sh2 – to connect a tachometer.

When a 300m mag is used, connect the mag cable to the camera connector Sh7. The tachometer should be plugged into the connector of the mag as shown at the Picture 8. This will power up the tensioning motor.

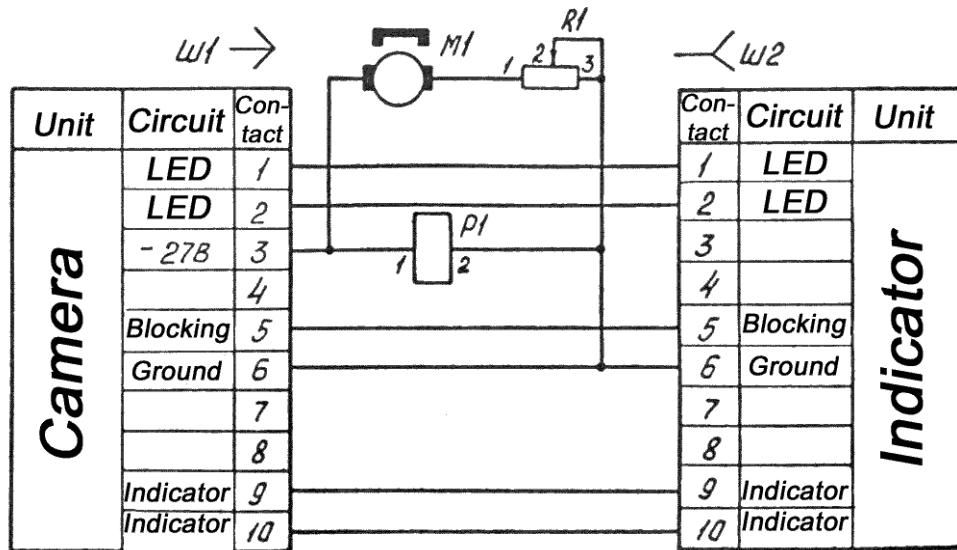

Picture 7. Electrical diagram of a 300m mag.

Table 5 is omitted. It contains a list of the electrical components of a 300m mag.

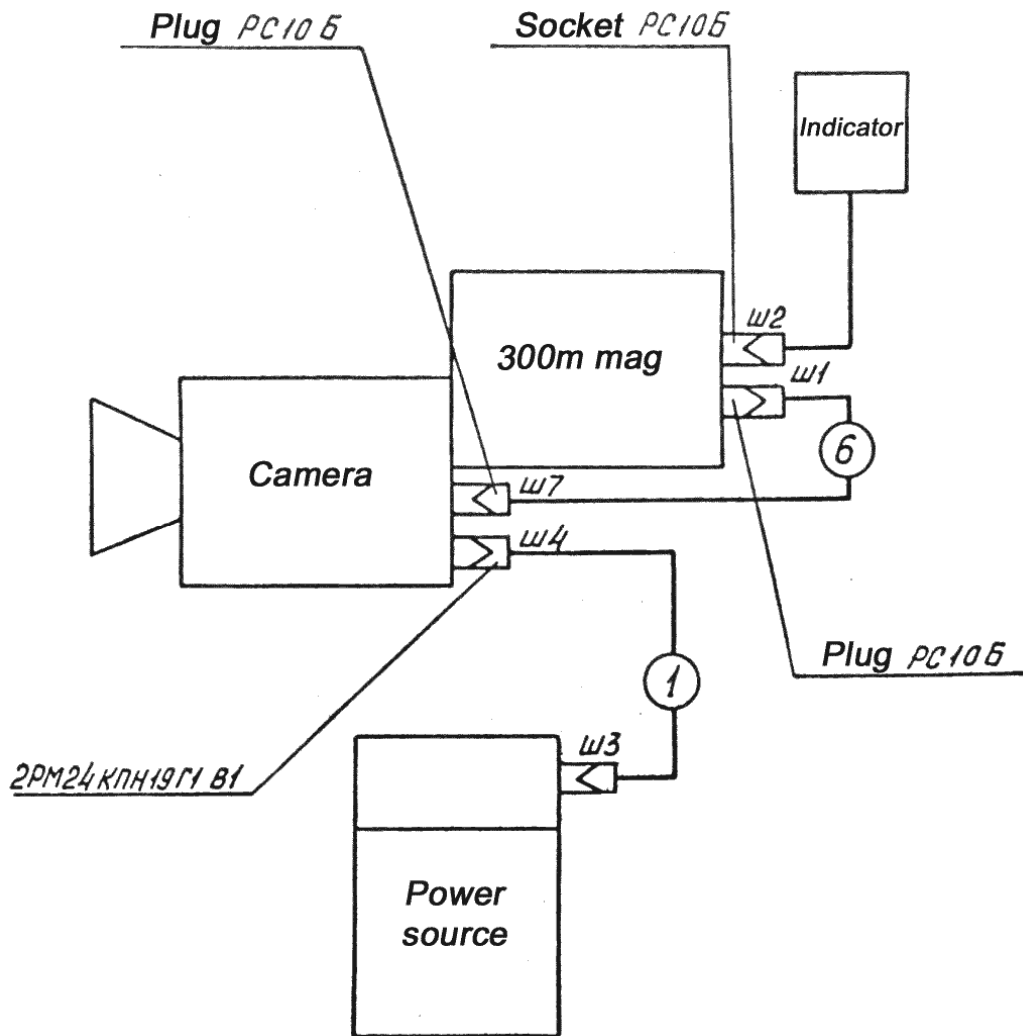

Picture 8. Electrical diagram of connections between the camera and a 300m mag.

### 5.5.4. Electrical diagram of the thermal control unit.

This diagram is shown in Picture 9.

The thermal control unit is a stand-alone unit similar to the control unit. It is firmly attached to a battery block and has a power switch marked "BKJI". It also has connectors for the heating units.

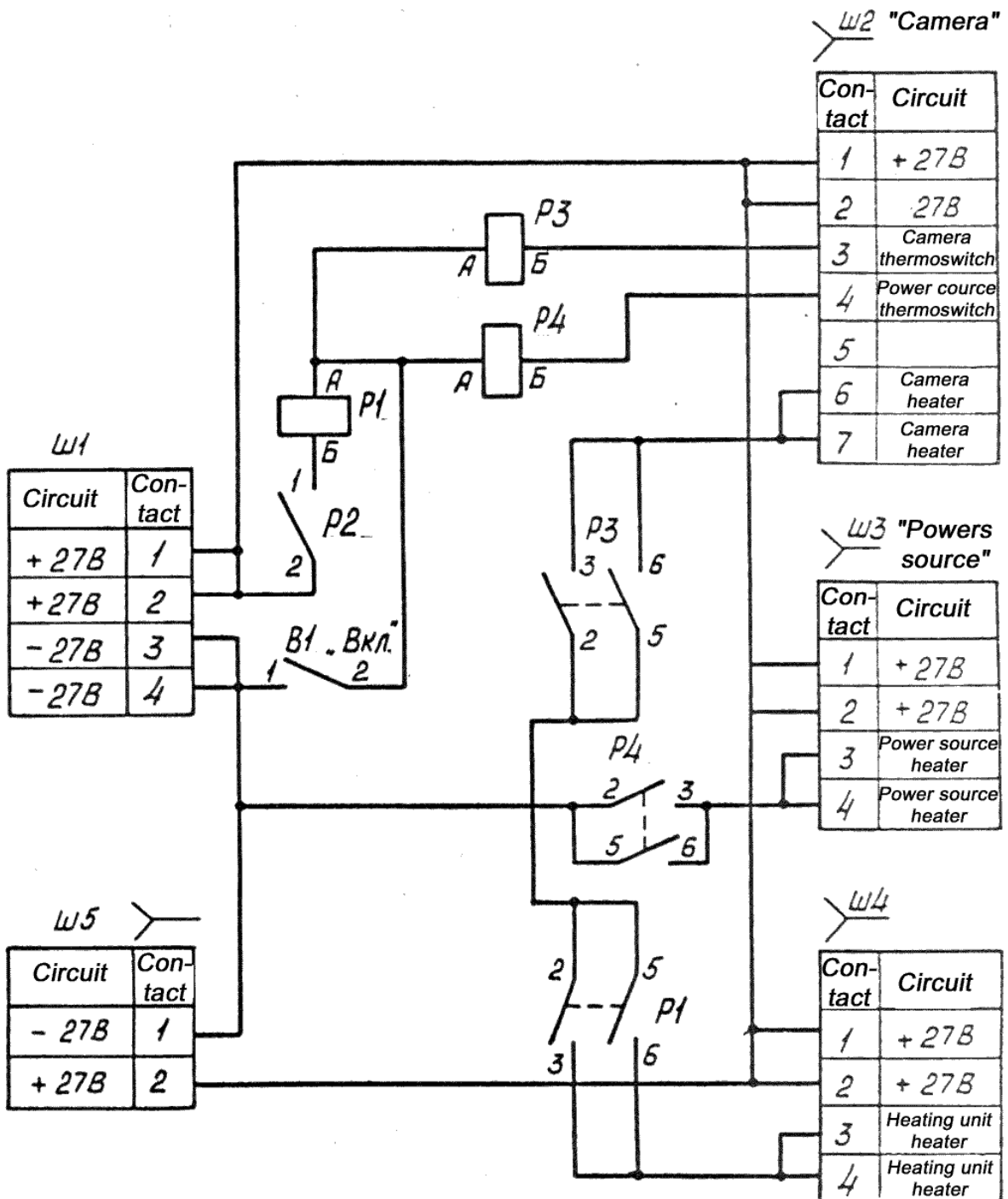

Picture 9. Electrical diagram of the thermal control unit.

Table 6 is omitted. It contains a list of the electrical components of the thermal control unit.

### 5.5.5. Electrical diagrams of the heating jacket.

These diagrams are shown at the Pictures 10, 11.

The heating jackets contain ten heating elements (for the camera) and seven elements (for batteries). They are connected in parallel. Each heating element has 120 Ohm electrical resistance.

The thermal control unit with the heating jackets should be utilized when the camera is used at temperatures below 20°C. Heating jackets should be powered from the batteries of the thermal control unit.

Electrical diagram of the camera with the heating system is shown in Picture 12.

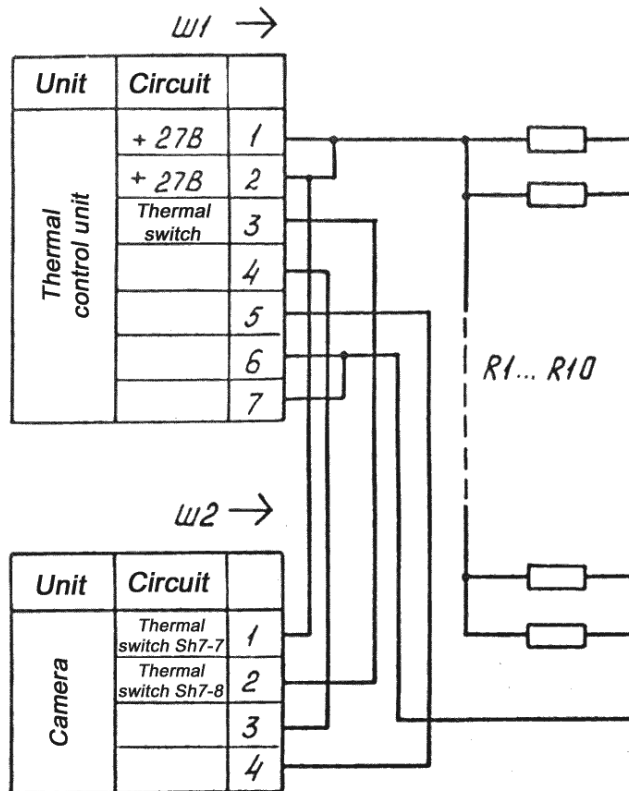

Picture 10. Electrical diagram of the camera heating jacket.

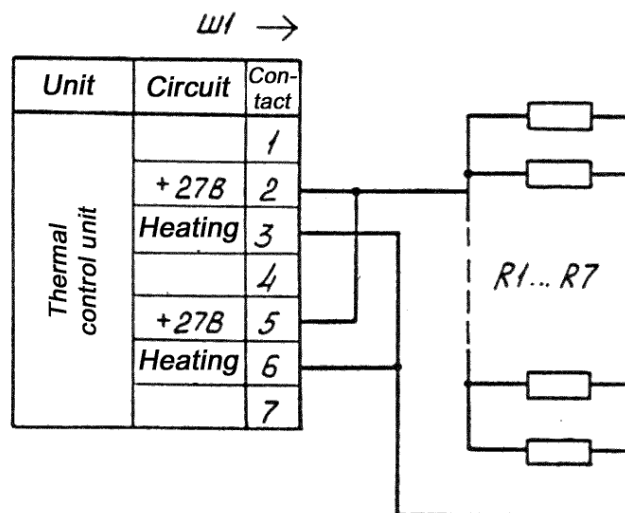

Picture 11. Electrical diagram of the power source heating jacket.

Table 7 is omitted. It contains list of the electrical components of the heating jacket.

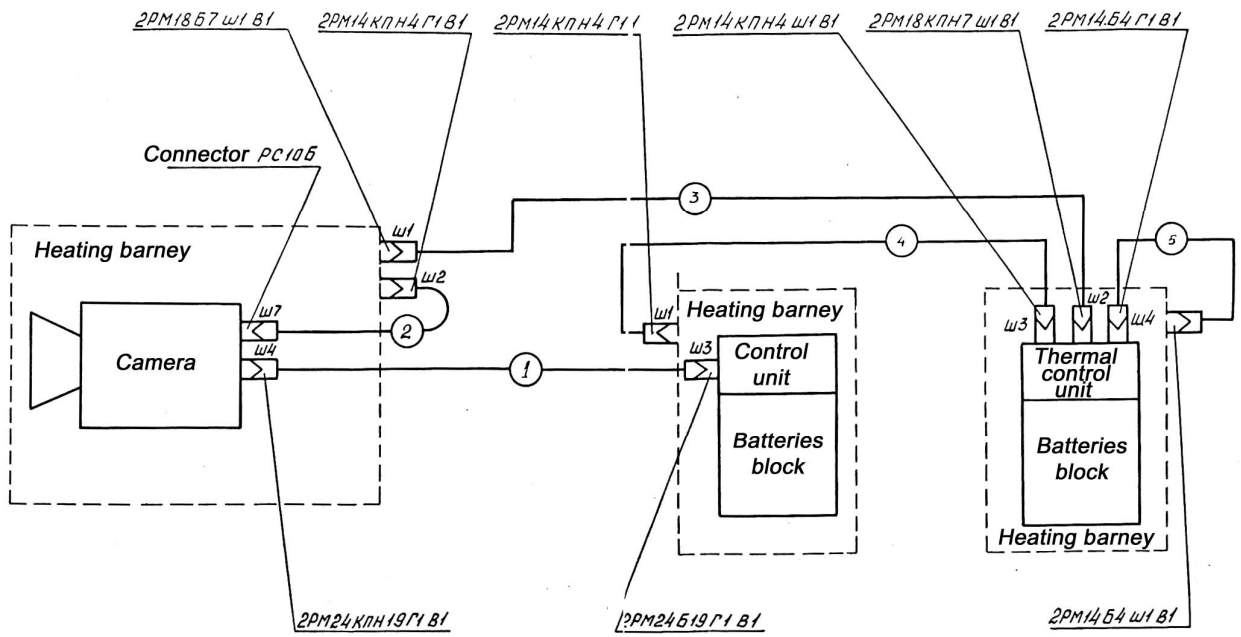

Picture 12. Electrical diagram of connection the camera with the heating units.

## 6. CONSTRUCTION AND OPEARION OF THE MAIN COMPONENTS OF THE CAMERA

### 6.1. The camera body.

The body has slots for the body door (86) (Picture 13), the shutter mechanism (77), the film transport mechanism (78), the support (79) for heavy lenses (Picture 14), the shooting speed knob (24) (Picture 13), the aperture change mechanism, the adapter for mag mounting (80), the FPS indicator (81), the intermittent mechanism (82).

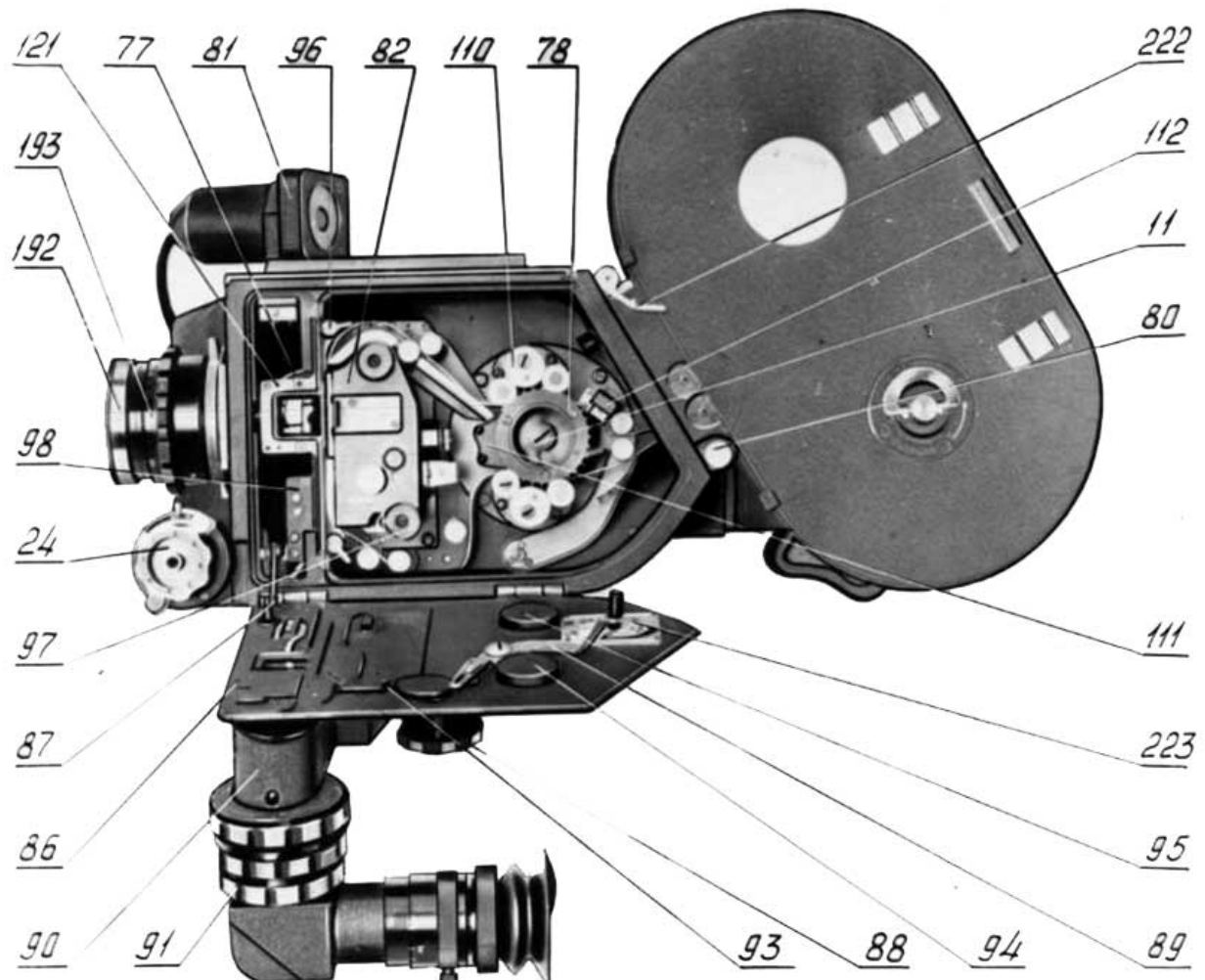

Picture 13. The camera with the door opened.

#### 6.1.1. The camera door.

The camera door (86) (Picture 13) covers the film transport mechanism. Its opening is restricted to 90° with a limiter (87).

The door can be locked and unlocked with the knob (88). The lever (89) opens/closes the mag port simultaneously.

The door has a tube (90) to mount interchangeable viewfinders (normal or wide-screen).

Installed viewfinder can be secured with the bayonet lock (91).

A lighting unit (92) can be installed onto the body tube. A signal lamp of this unit lights up when aperture of a lens reaches its limit value during work with an aperture change mechanism.

This signal is visible in the viewfinder outside of the frame as a red rectangle.

Turning prism is closed by a cap when it is in non-operational condition.

The camera door has blocking units (93, 94, 95) that don't allow the door to be closed if locks (96) of the front film gate are opened, or if the intermittent movement mechanism securing cones (97) are not tightened, or if keepers are opened.

The signal lamp of the lighting unit is powered through the contact block (98).



Picture 14. The camera with a 300mm lens and support for heavy lenses.

## **6.2. Construction of the camera.**

The camera consists of the shutter mechanism, the film transport mechanism, and the intermittent movement mechanism.

### **6.2.1. The shutter mechanism.**

The body of the shutter mechanism is secured to the motor (1) with four screws (Picture 15). The motor is connected to a speed transducer with a play-free coupling.

The body of the shutter mechanism has a cut-out used to turn it manually if necessary.

The speed transducer is secured with stop screws (102) in alignment with the motor.

Inside the body is the mirror shutter unit (6).

The body has columns (103) used to install the intermittent movement mechanism and film gate with a collecting lens for the viewfinder.

The body also contains the built-in start button (104). Rear part of the body contains a printed circuit with electrical components of the camera.

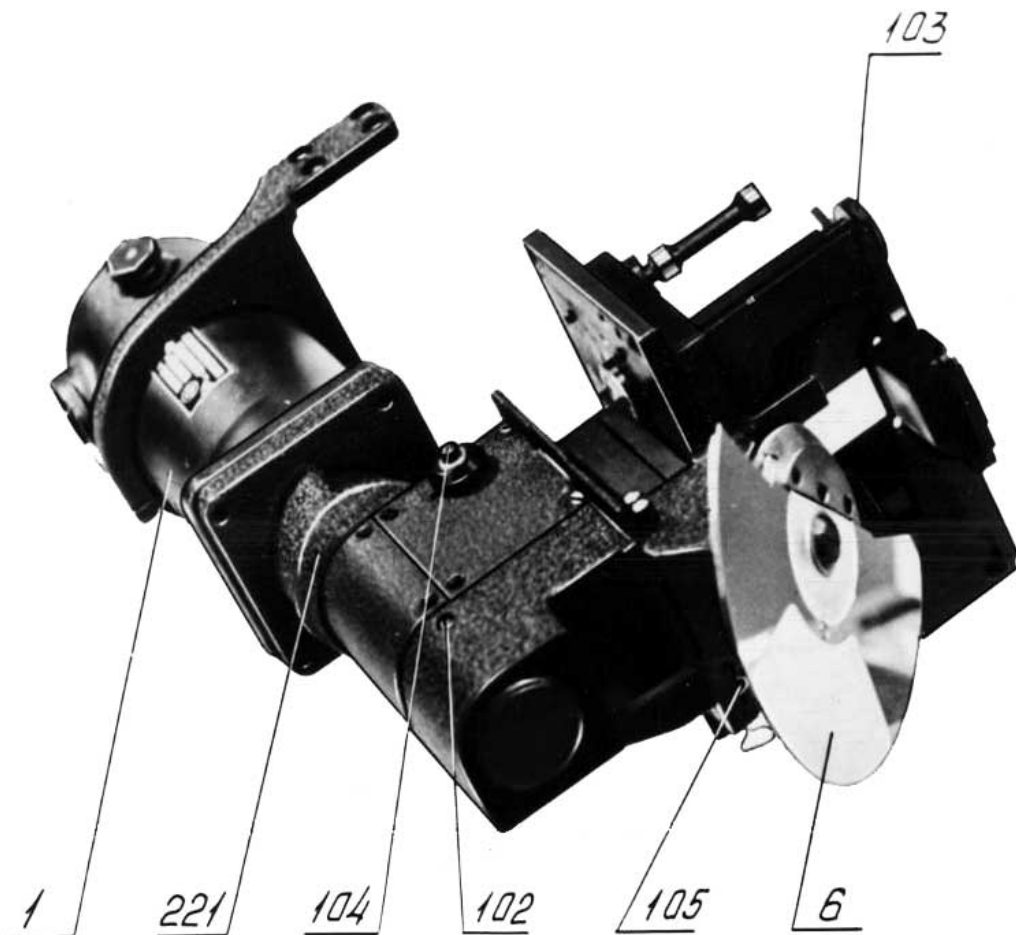

Picture 15. The shutter mechanism.

### 6.2.2. The film transport mechanism.

The axle of the mechanism (Picture 13) has a 32-teeth sprocket (11) with keepers and film strippers. There is also a geared ring on the axle (132 teeth).

Unit (112) serves to make a light mark on the film.

### 6.2.3. The intermittent movement mechanism.

This mechanism (82) (Picture 13) is assembled in a separate unit.

Some of the intermittent mechanism elements are set on bearings (a main shaft, a supplementary shaft, a connecting-rod, and a cross-beam). The supplementary shaft is assembled as a separate unit which is secured to the body of the mechanism by screws.

Output shaft of the intermittent mechanism has a half-coupling (116) (Picture 16) with lugs to connect to the input shaft of the camera mechanism.

There is a bushing (117) in the top part of the mechanism, and the plate (118) with a flare in it to mount the intermittent movement mechanism onto the camera. It is secured with the cones (97) (Picture 13).

The double-tooth pulldown claws (119) (Picture 16) pull the film through the film channel.

The double-tooth registration pins (120) hold the film during exposure.

The front slide rails (121) (Picture 13) are not connected to the intermittent movement mechanism.

The rear slide rails (122) (Picture 16) have the built-in pressure plate (123).

The gap between the front and rear sliding rails is 0.3mm. The gap between front the rails and the clamping frame is 0.14mm.

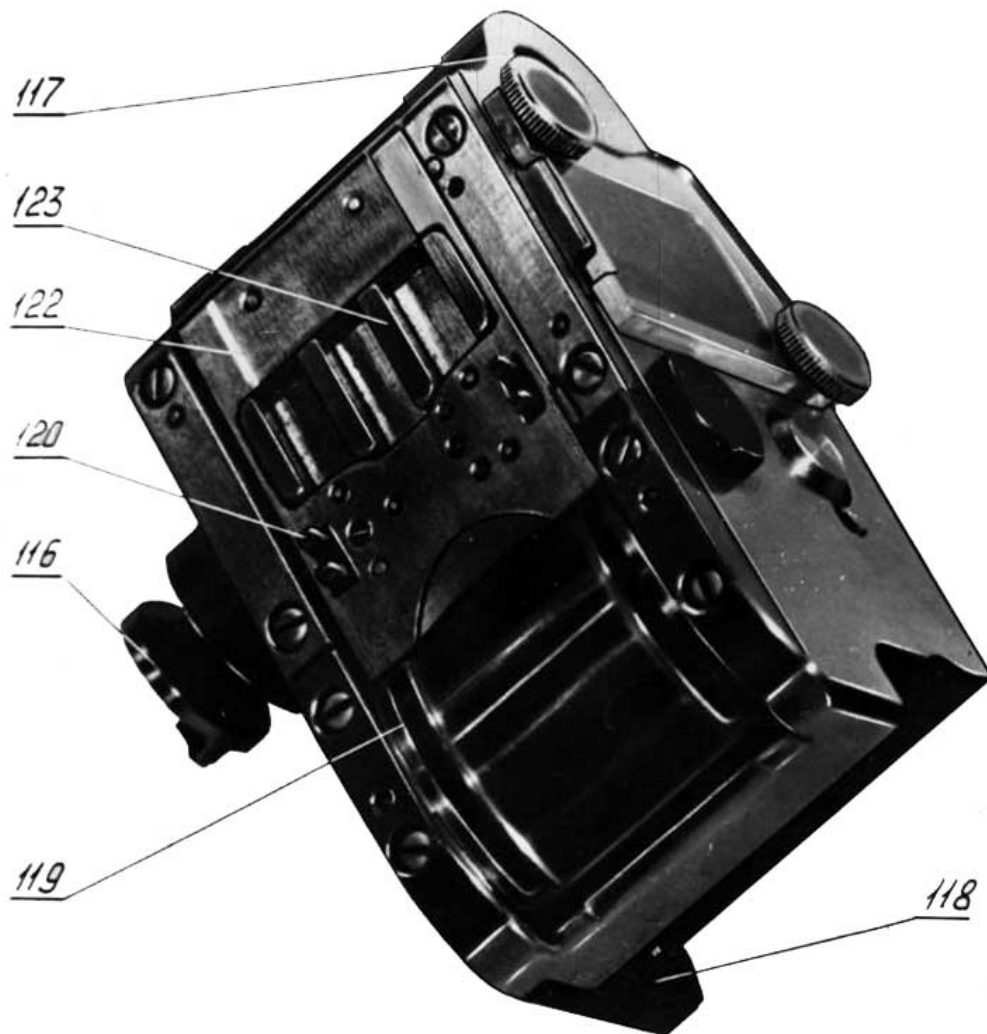

Picture 16. The intermittent movement mechanism.

### ***6.3. The aperture change mechanism for zoom lens 35OPF15-1A.***

This mechanism provides a constant exposure of the film when changing the camera speed from 24 to 150 FPS.

This mechanism is designed for the lens 35OPF15-1A. It is electrically connected to the camera through the floating connector RP-10 (Picture 5). When the lens 35OPF15-1A is used, it is necessary to determine brightness of the subject first and to set the corresponding aperture value. The camera speed knob should be set to 24FPS position. Kinematics of the aperture change mechanism should be disabled by pressing handle (127) (Picture 17).

When you change the camera speed, each marked speed value corresponds to one of the lens aperture values.

Depending on the shooting plan, you may set the limiters (128) on the speed knob to selected limit values.

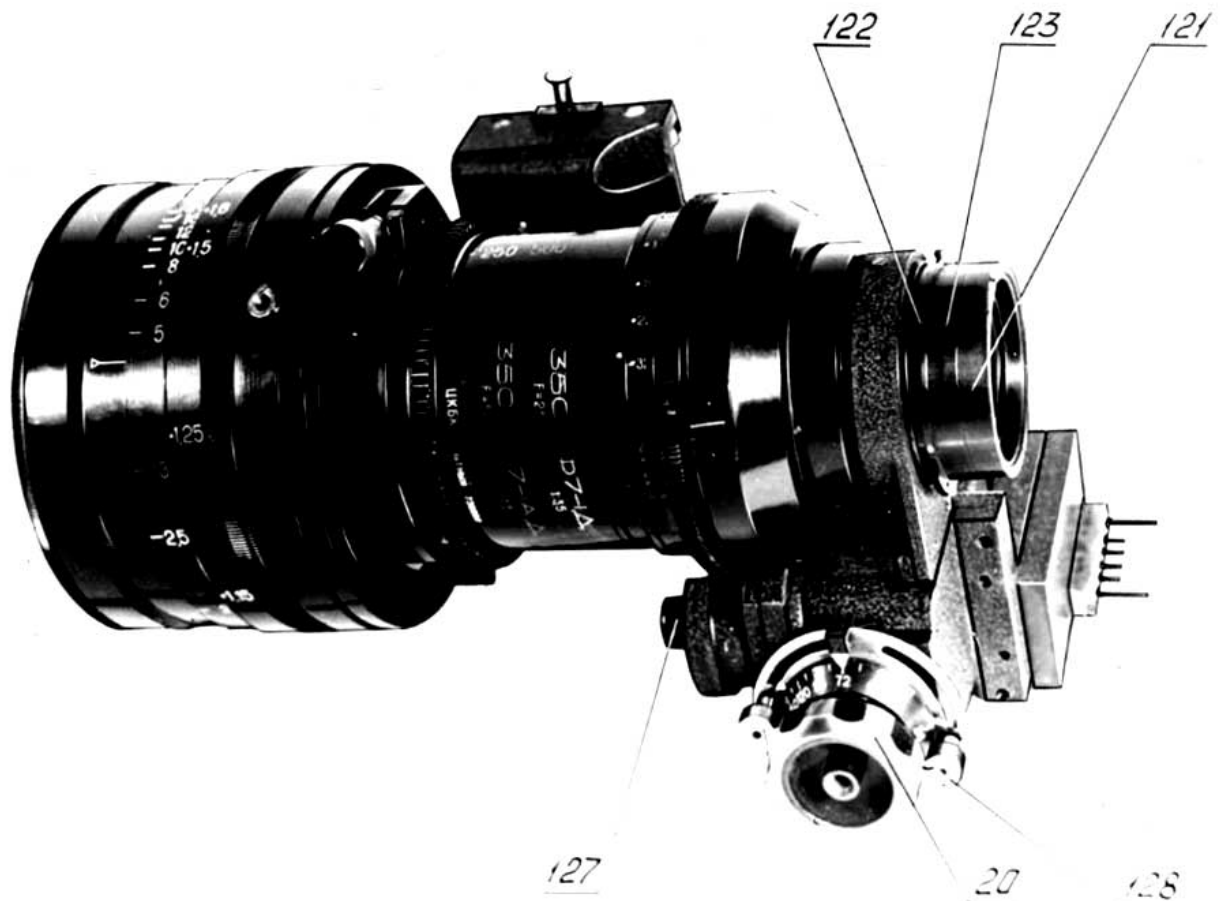

Picture 17. The aperture change mechanism for the 350PF15-1A lens.

#### **6.4. The aperture change mechanism for 200mm and 300mm lenses.**

This mechanism provides a constant exposure of the film when you change the camera speed from 24 to 150 FPS using a 200mm or 300mm lens.

Optical density of some parts of frames will not change more than 0.05 with the working contrast coefficient.

When this mechanism is used, it is necessary to determine brightness of the subject first and to set corresponding aperture value with the control handle (131) (Picture 18). Marked value “24” of the FPS scale (132) should be set against value “11” of the diaphragm (133).

When you change the camera speed with the knob (131), each marked speed value corresponds to one of the lens aperture values.

Depending on the shooting plan, you may set the limiters (134) on the speed knob to necessary limit values.

If the lens aperture reaches its limit value, you’ll see a red rectangular warning symbol outside of the frame field in the viewfinder.

If you want to change shooting speed without changing the aperture value, you can disconnect the aperture change mechanism temporarily by continuously pressing the button (135).

It is necessary to use the heavy lens support (79) (Picture 14) if you want to use a 200mm or 300mm lens with the aperture change mechanism.



Picture 18. The aperture change mechanism with a 300mm lens.

### 6.5. A 120m mag.

The mag has a common chamber design that allows a shorter distance between spindles.

The mag capacity is 120m of film.

The detachable side lid (140) is secured to the mag body with two locks (141). The lid has the handle (142) to turn the take-up spindle (13) manually.

The film counter (143) on the rear side of the mag shows length of the remaining unexposed film in the mag. This counter is driven by the lever (144) that clears space for a film roll when the mag is open. When the mag lid is attached in its place, the lever is pressed toward the film roll, and the counter shows the correct value.

There are chromed steel film guides (145) on the inner sides of the lid and the mag body. These limit displacement of film reels when the camera is tilted.

Film goes out of the mag and back in through the self-closing window that is opened by the lever (89) of the camera door (Picture 13).

The take-up spindle (13) (Picture 19) and feed spindle (19) have drag clutches set to specified braking torque.

Take-up spindle also contains a spring (reverse movement coupling) allowing the core to turn in forward direction only. This prevents the film unwinding when the mag is removed from the camera.

Torque on the take-up spindle is 0.2 N·m (2000 g·cm), on the feeding spindle – 0.1 N·m (1000 g·cm). These torques can be adjusted by tension of springs inside spindles.

The take-up spindle is driven by the geared ring (17) (Picture 2).

There are plates (146, 147) (Picture 19) on rear sides and lids of mags to write notes on.

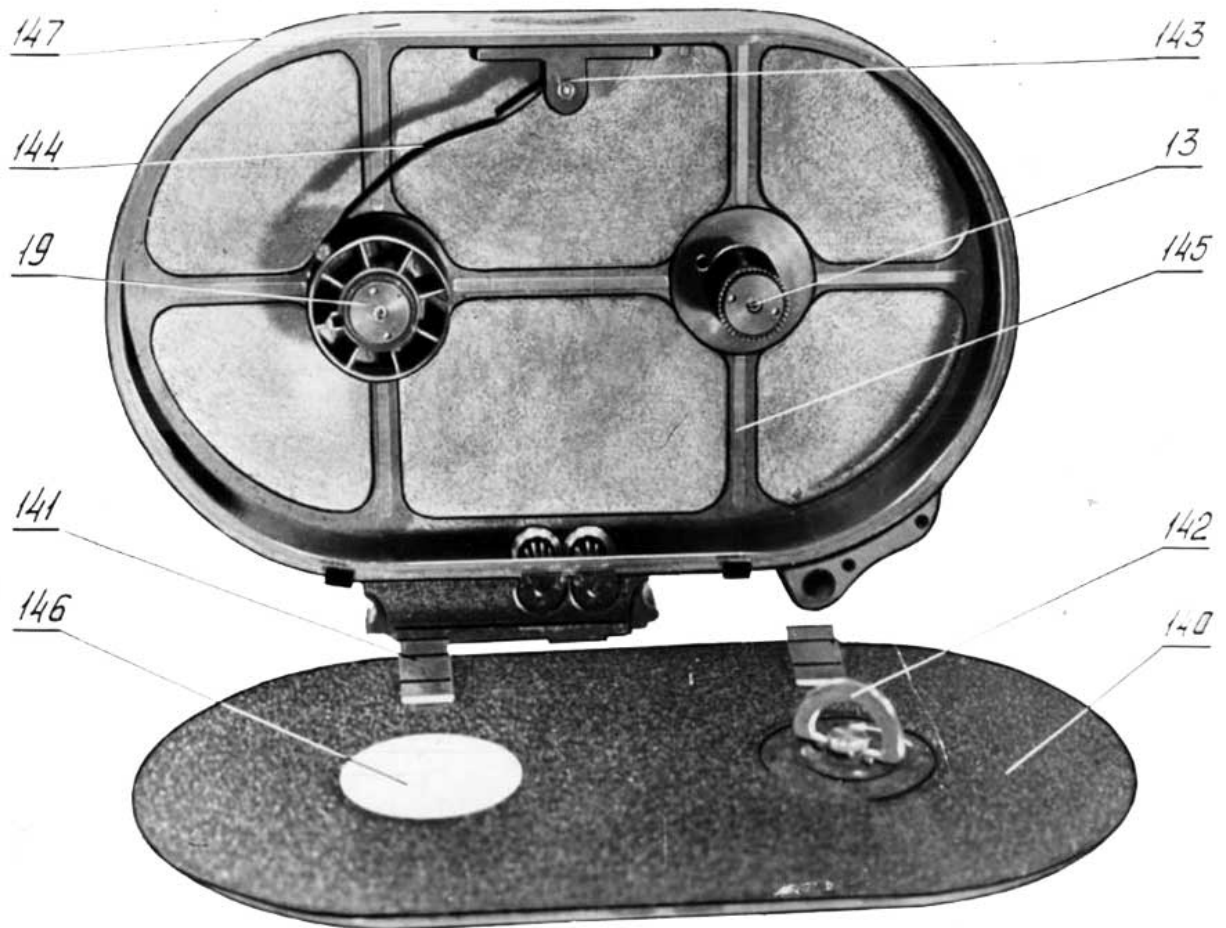

Picture 19. A 120m mag.

### 6.6. A 300m mag.

This mag (Picture 14) is necessary to shoot at high speeds when frequent changes of 120m mags would be undesirable.

The mag has a common chamber design.

The detachable side lid (152) is secured to the mag body with two locks (153). The lid has the handle (154) to turn the take-up spindle manually.

The film counter (155) (Picture 90) on the rear side of the mag shows length of the remaining unexposed film in the mag. This counter is driven by the lever (156) that clears space for the film roll when the mag is open. When you attach the mag lid to its place, the lever is pressed toward the film roll, and counter shows the correct value.

There are chromed steel guides (157) on the inner sides of the lid and the mag body. These limit displacement of film rolls when the camera is inclined.

The film goes out of the mag and back in through the self-closing window that is opened by the lever (89) of the camera door (Picture 13).

There are two friction adjustments ahead of the take-up spindle. The camera friction is set to 0.15 N·m torque (1500 g·cm). The additional motor friction is set to 0.27 N·m torque (2700 g·cm).

These torques can be adjusted by the tension of spiral springs.

Torque on the feeding spindle is 0.1 N·m (1000 g·cm).

There are white plastic plates (158) (Picture 14) on the rear side and lid of the mag to write notes on.

The mag power cable should be connected to a connector situated perpendicularly to the mag plane. The FPS indicator cable should be connected to the connector on the rear of the mag body.

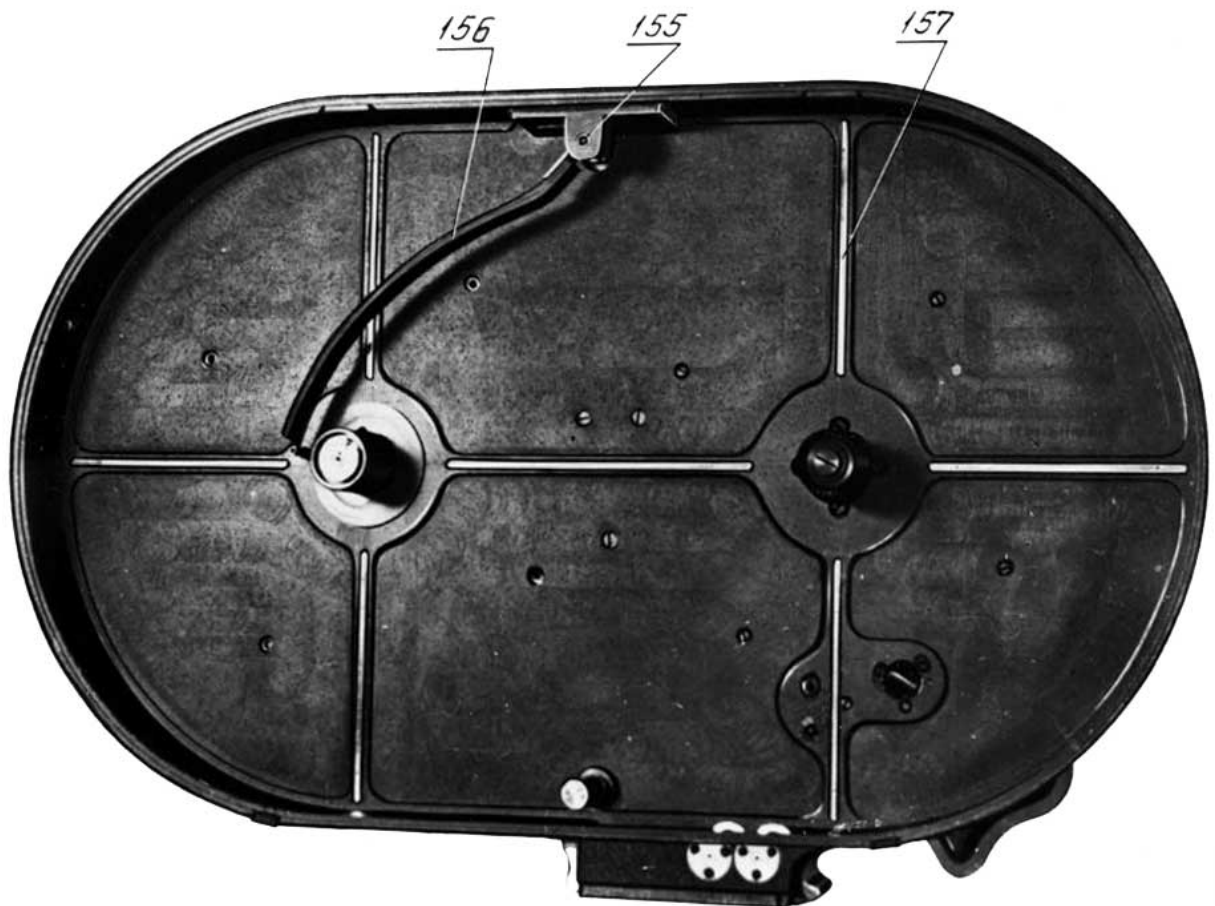

Picture 20. A 300m mag with removed lid.

### ***6.7. The shooting speed knob.***

The purpose of this knob (25) (Picture 21) is to change shooting speed smoothly in the range between 24 and 150 FPS.

This knob is electrically connected to the camera with the floating connector RP-10-7. Shooting speed can be limited by means of adjustable stoppers (165).

It is possible to mount the handle (166) to the knob for convenient operation.

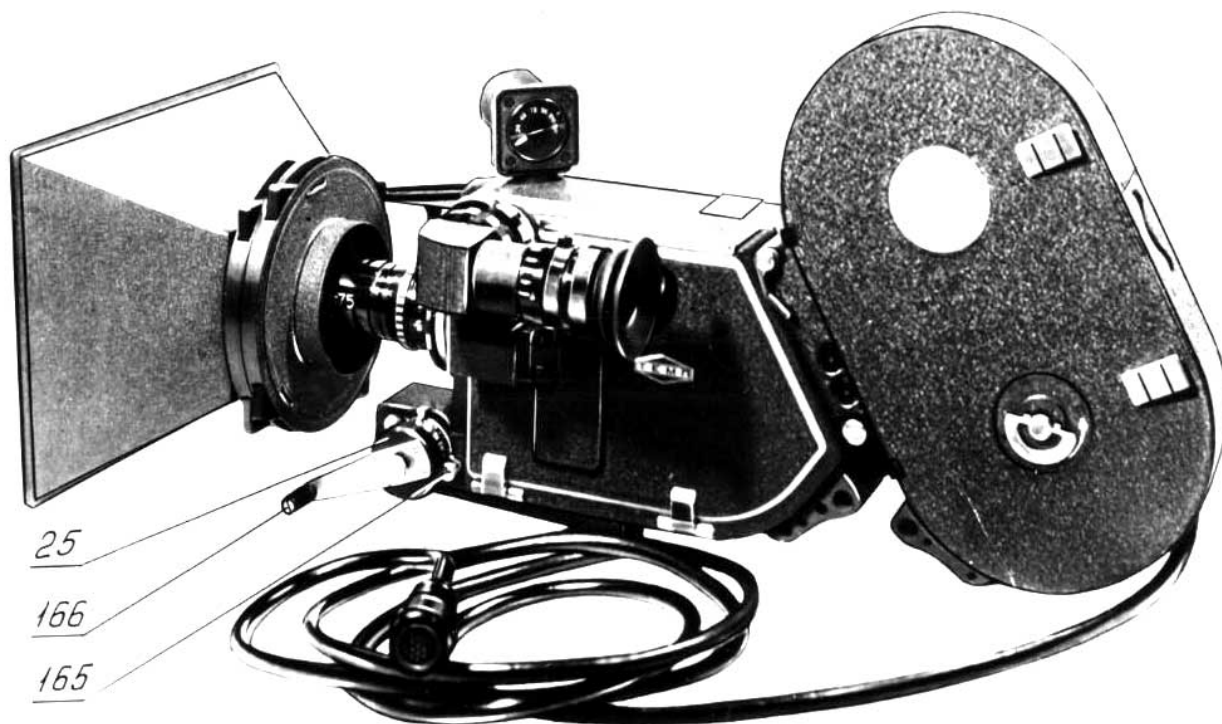

Picture 21. The camera with a 75mm lens.

### 6.8. Viewfinder.

Each viewfinder consists of two parts – a tube (90) (Picture 13) and interchangeable eyepiece elbows for normal and wide-screen shooting.

The eyepiece (69) (Picture 14) is mounted to the tube. The eyepiece provides a correctly oriented magnified image without parallax distortions.

The interchangeable eyepieces (170, 171) (Picture 22) are secured on the camera by the lock (172). They have a light-protecting door (173), and diopter adjustment ring (174) with securing nut (175).

The viewfinder can be used with the operator's right or left eye. Also, it can be moved up and down, forward and backward for the operator's convenience. It can be secured in position with a turn of the ring (176).

There is soft rubber eyecup (177) at the end of the eyepiece. Eyepieces are marked with a letter "A" (anamorphic) or "H" (normal).

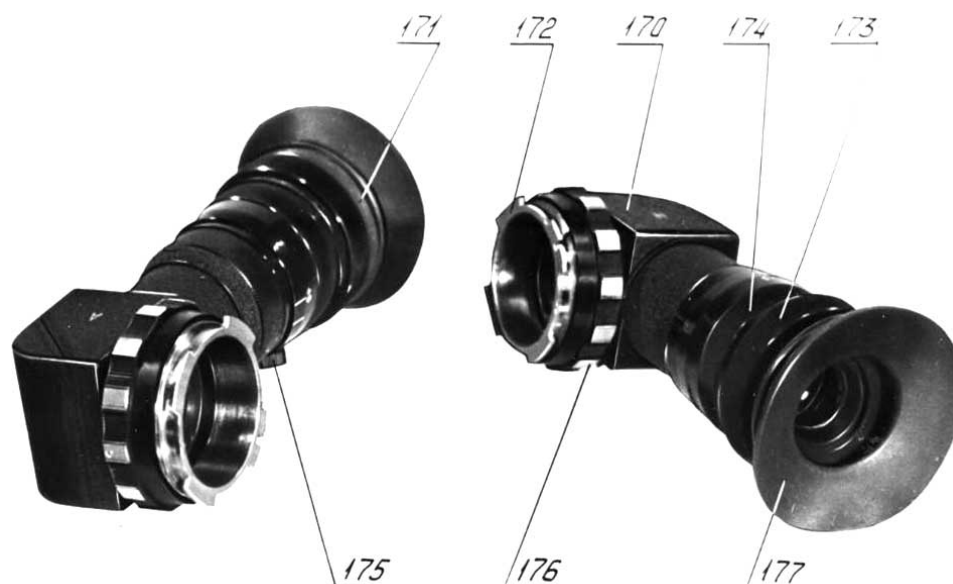

Picture 22. Viewfinder with interchangeable eyepiece elbow for normal and wide-screen shots.

### **6.9. Lenses in focusing mounts.**

The camera is supplied with ten interchangeable lenses allowing shooting from 0.5m to infinity. A lens focal length should be chosen according to the shot type.

A lens can be set in one position only (determined by an alignment pin in the camera mount and alignment slot on the lens mount). Flange focal distance of lenses is  $57 \pm 0.01$  mm.

Lenses are secured with a breech lock.

Lenses can be focused with the focus ring (192) (Picture 13). When you turn this ring, a lens optical block moves along optical axis without rotation.

Aperture can be set by the diaphragm ring (193).

The focusing and diaphragm ring have distance and aperture scales marked on them.

### **6.10. The heavy lens support.**

It is used to support 200mm and 300mm lenses.

When a 300mm lens is used, the bracket (195) (Picture 23) should be removed. Similarly, when a 200mm lens is used, the bracket (196) should be removed.

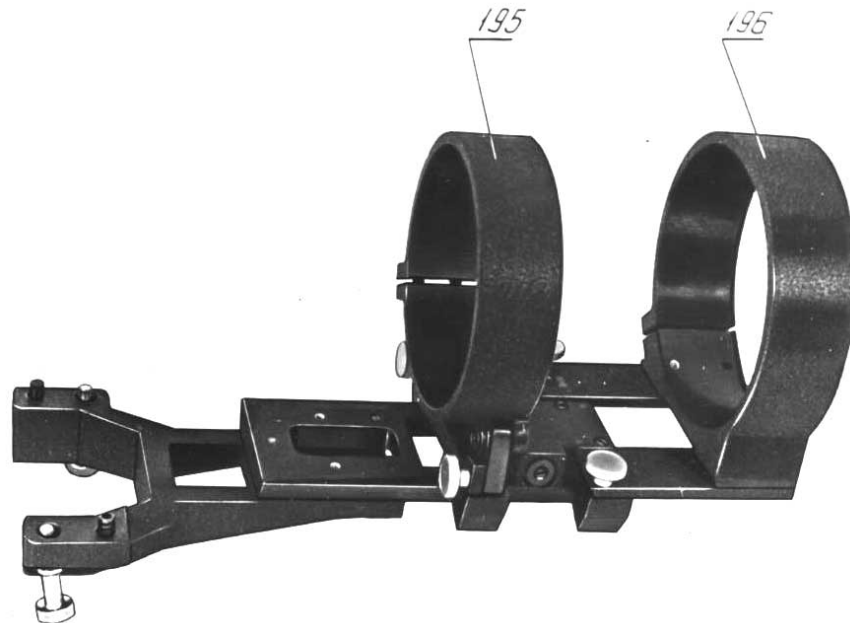

Picture 23. The heavy lens support (for 200mm and 300mm lenses).

### **6.11. The FPS indicator (tachometer).**

This indicator (81) (Picture 13) is stand-alone unit. It can be mounted on top of the camera. It is electrically connected to the camera with a flexible cable.

Functional principle of the indicator is described in section 5.5.1.

### **6.12. The power source.**

The power source contains two battery blocks (198) (18SCS-5) and (199) (18SCS-15) (Picture 24).

The battery block 18SCS-5 has smaller weight and dimensions, so it is more widely used.

The battery block 18SCS-15 is intended for long continuous high-speed shots without recharging batteries, or during operation with higher power consumption (in cold temperatures, for example).

The control unit (200) is connected to the camera with a cable. When hand-holding, a 1.2m cable can be used. When shooting from a tripod, it is more convenient to use the longer (3m) cable to put the battery in suitable place.

The control unit has following controls:

- 1) The power switch (201) with "IINTAHNE" and "BKJI" marks;

- 2) The operation mode switch (202) to set either fixed sync 24FPS mode, or mode allowing adjustment of the shooting speed in the 24-150FPS range.
  - 3) The remote control switch (203) with “KAMEPA” and “IIYCK” marks.
- There is a carrying belt (204) attached to the top part of the control unit.

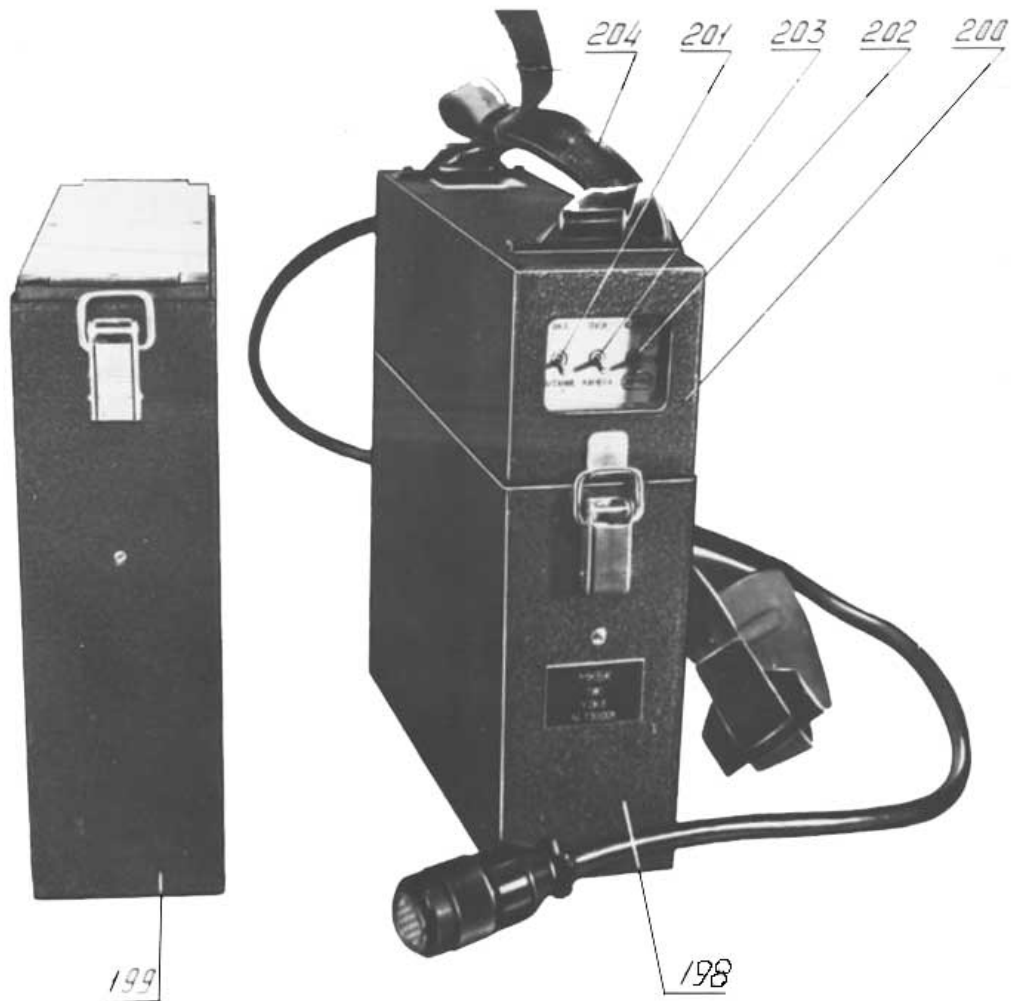

Picture 24. The power source.

### ***6.13. Electrical heating unit.***

This unit is intended for powering of the thermal control system of the heating units for the camera and power sources.

It has a shape similar to the power source of the camera. There is a block of batteries SCS-15. There is a power switch marked “BKJI” and connectors (208, 209) (Picture 25) for the soft heating jackets. There is also a carrying belt (210).

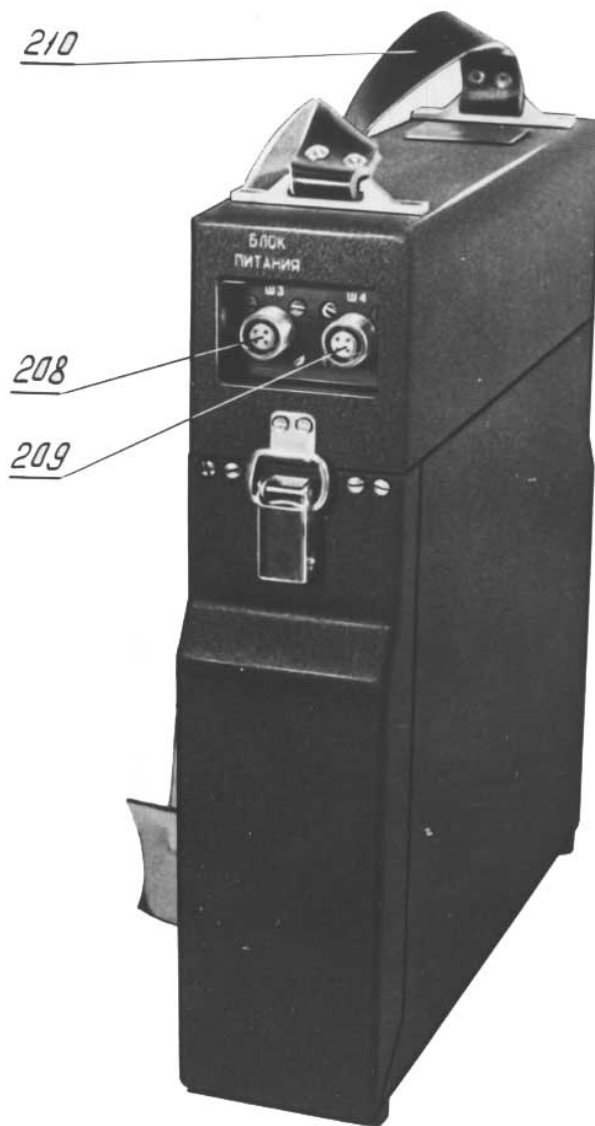

Picture 25. Electrical heating unit.

### **6.14. A shoulder support.**

This shoulder support is used to help the operator to hold the camera steady, especially when heavy lenses are used.

The bottom support (213) (Picture 25) can be adjusted vertically. The base plate (214) provides the ability to set the camera horizontally, vertically, or at an angle. When you change the position of the arms (215, 216), the angle of the base plate changes accordingly.

The shoulder support can be secured on an operator's body with the waist belt (217) and the vertical belt (218).

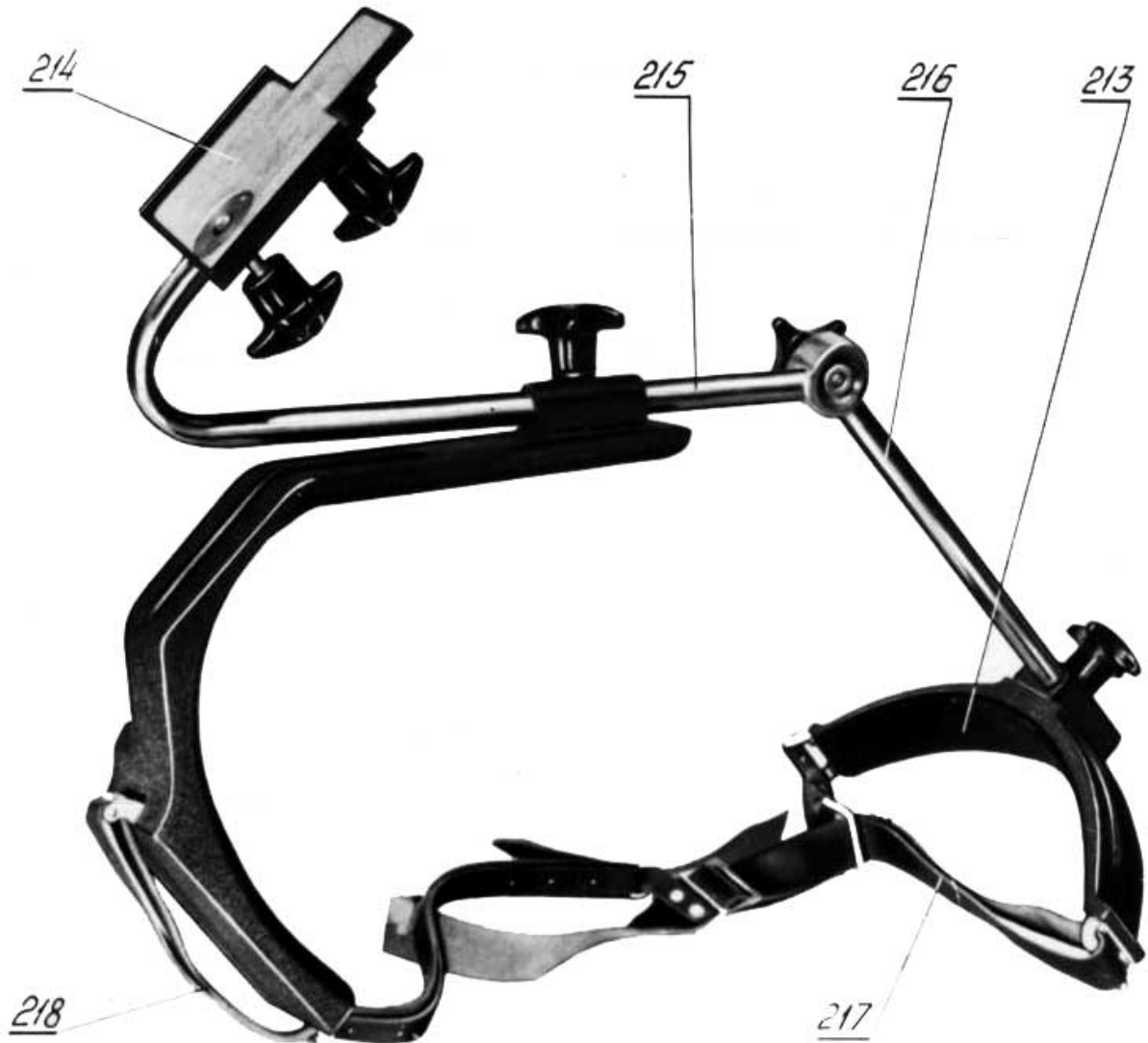

**Picture 26. The shoulder support.**

### **6.15. The heaters for the camera and for the power source.**

These heaters allow the camera and power source to operate at cold down to  $-30^{\circ}\text{C}$ .

The soft jackets are covered with a water resistant material, and contain heating elements.

Power requirement of the elements in the camera unit is 120 W.

Power requirement of the elements in the power source unit is 80 W.

The camera heater can be used with the following setup:

1) The camera without FPS indicator, with following parts:

- shooting speed knob;
- 120m mag;
- normal viewfinder;
- cable;
- 50mm lens;
- deanamorphic viewfinder;

2) 22, 28, 35, 75, 100, 150, 200, 300mm lenses without the heavy lens support:

3) 35, 50, 75mm anamorphic lenses;

4) lens hoods.

### **6.16. Film gates with shifted frame window "HC", "AC".**

These film gates are designed to achieve a reverse movement effect during forward movement of the film.

The only difference of these film gates from the usual ones is to shift the frame window 2.55mm toward the base side of film.

Misplacement of the image on the viewfinder ground glass will be not more than 0.15mm. Left side of the frame will get beyond field of view of the viewfinder.

These film gates with shifted frame window "HC", "AC" are interchangeable with usual film gates on the columns of the camera intermittent movement mechanism.

### **6.17. Transport case.**

Its purpose is to carry the camera kit when traveling.

It has special slots for different parts of the camera kit.

The following parts can be stored in this box:

1) the camera with following parts installed:

- normal film gates – 1;
- FPS knob – 1;
- lens port cover – 1;
- mag – 1;
- viewfinder port cover – 1;

2) the control unit – 1;

3) the normal viewfinder – 1;

4) a mag – 1;

5) the 200mm lens – 1;

6) the 1.2m cable – 1;

## **7. MARKING AND PACKING**

Marking and packing is done according to OCT3-3076-78.

## **8. GENERAL OPERATING INSTRUCTIONS**

If the camera will be used at low temperatures (from 0°C down to -20°C), it should be prepared for the winter mode. To do this, wash the camera mechanism and mag mechanism in pure kerosene or other suitable solvent.

Do not wash the bearings. You should clean them with a clean cloth.

After washing, lubricate the camera mechanism with grease OKB-122-7 GOST 18172-72. For the intermittent movement mechanism, guiding rollers and keepers, use instrument oil VNII NP-6-TU38-001168-74.

Clean lens mounts carefully and lubricate their working threads with grease OKB-122-7 GOST 18179-72.

At cold temperatures, use the battery block SCS-15 in the soft case (probably without heater).

At extremely cold temperatures (of -20°C to -30°C) both the camera and power source should be placed into the cases with heaters.

## **9. SAFETY MEASURES**

The camera meets GOST 12.2.007.0-75, protection class is O1.

## **10. PREPARATION FOR WORK**

Examine all parts of the kit first. Remove all dust, especially from the film channel. Turn the camera mechanism by hand, and try to run it without film briefly to make sure that it works.

### ***10.1. Loading a mag.***

Clean the mag of dirt and dust, and follow the instructions below:

- 1) pull the locks (141) (Picture 19) and open the mag lid (140);
- 2) pull the film counter lever (144) to the top fixed position;
- 3) install 120m film roll (wound on a standard 50mm film core emulsion outward) onto the feeding spindle (119) so that film can be unwind counter-clockwise;
- 4) make about 20cm film loop between two rollers in the mag opening, and attach the film end to the take-up core (13). The film should wrap around the core firmly, and be in a taut state. Film should be wound onto the take-up core counter-clockwise;
- 5) close the mag lid (140) pulling its locks (141);
- 6) mark the film type, length, loading date, and the loader's name on the plates for notes. 300m mag should be loaded in the same manner.

### ***10.2. Loading the camera.***

- 1) Open the camera door (86) (Picture 13);
  - 2) turn cones (97) of the intermittent movement mechanism and open the keepers (110);
  - 3) pull the intermittent movement mechanism away from the film gate (121) with the registration pins (120) (Picture 16) in the rear position. The fork can be set in rear position with turn of the handle (121) (Picture 15) counter-clockwise.
  - 4) open the film gate locks (96) (Picture 13) and remove it from the camera;
  - 5) clean oil and dust from the film gate and film rails in the camera with a soft cloth. "Scale" can be removed with a napkin moistened in spirits;
  - 6) install the film gate and secure it with the locks;
  - 7) pull a film from the mag to the mark on the mag body;
  - 8) turn the handle (222) to open the mag lock on the camera. Remove the mag port cover and place it into the camera box;
  - 9) install the mag into the mag port of the camera. Pass the film into the camera and secure the mag by turning the handle (222). When you install a mag, turn the camera mechanism by hand to allow camera and mag gears to mesh with each other;
  - 10) load the camera mechanism according to the diagram (223) located on the camera door, or as shown at the Picture 26. Set the intermittent movement mechanism and keepers to the working (closed) position. Loop markers before and after the mechanism show maximum allowed loop sizes;
  - 11) turn the transport mechanism by hand to check loops. They should not stretch or touch the camera body. The loop before the take-up core should be reduced by turn of the handle (142) (Picture 19);
  - 12) close the camera door (86) (Picture 13) and secure it by a turn of the handle (88). At the same time, the window of the mag will open.
- Note. Never attempt to install a mag when the camera door is closed.

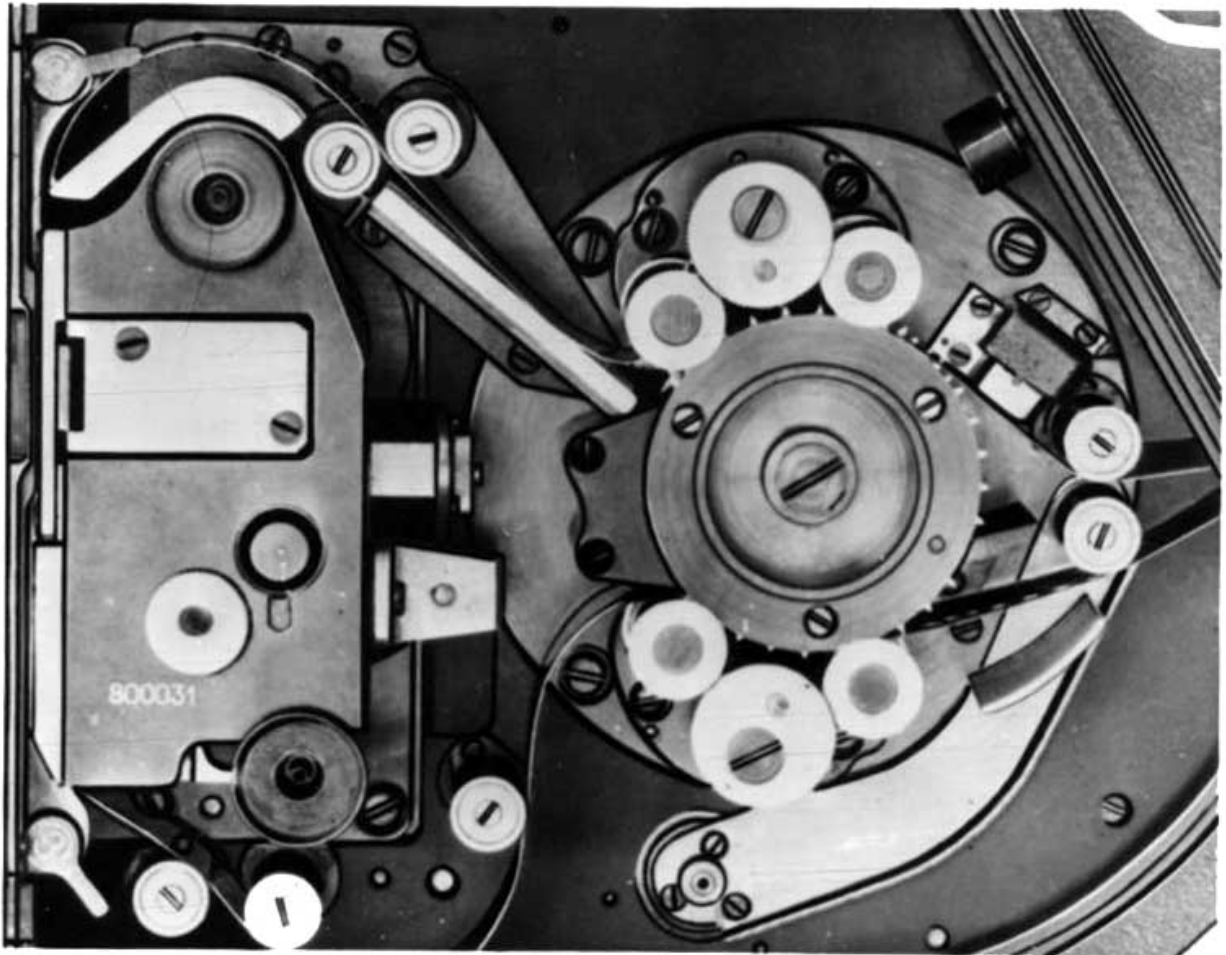

Picture 27. Loading the camera.

### ***10.3. Mounting of light protecting devices.***

Install the matte box for 18-150mm lenses onto the heavy lens support and secure it with a screw.

Insert a matte corresponding to the mounted lens focal length.

Matte box for 50mm and 75mm anamorphic lenses should be mounted on the lens bracket. The same matte box can be mounted onto a 35mm anamorphic lens through an adapter. Insert a matte corresponding to the mounted lens focal length.

Rear tube of the matte box is interchangeable and should match the mounted lens too.

For the zoom lens 35OPF15-1A, a special matte box should be mounted through an adapter.

### ***10.4. Mounting of the aperture change mechanism onto 35OPF15-1A zoom lens.***

For typical shooting, install the mechanism onto an adapter bush and secure it with a ring, so that after mounting lens onto the camera, the mechanism's electrical connector pops into its jack on the camera.

Press the button (135) (Picture 18) to disconnect the mechanism gear from the lens diaphragm gear, and set necessary aperture value in accordance with the shooting speed (set with the shooting speed knob) and light conditions.

### ***10.5. Mounting of the aperture change mechanism for 200mm and 300mm lenses.***

Align the mechanism and a lens by the groove (225) (Picture 28).

When you mount the bracket onto the 200mm lens, the stop collar (226) should be positioned with its protruding flange (227) toward the bracket.

When you mount the bracket onto 300mm lens, the stop collar should be positioned with its protruding flange outward of the bracket.

The mechanism is secured on the lens with a retention hoop (196) (Pictures 18, 28).

The mechanism is electrically connected to the camera with a flexible cable (228) through a floating connector RP-10.

After the mechanism is installed, press the button (135) (Picture 18) and set the correct catch of the mechanism with the lens diaphragm ring.

Value "11" on the lens diaphragm ring (229) (Picture 19) should correspond a value on the control knob index mark (230). The tappet (231) (Picture 28) should correspond to the mounted lens focal length. The linear scale (133) (Picture 18) of the calculator diaphragm should be set against an index mark. Value "24" of the shooting speed scale (132) should be set against the mark and diaphragm value "11".

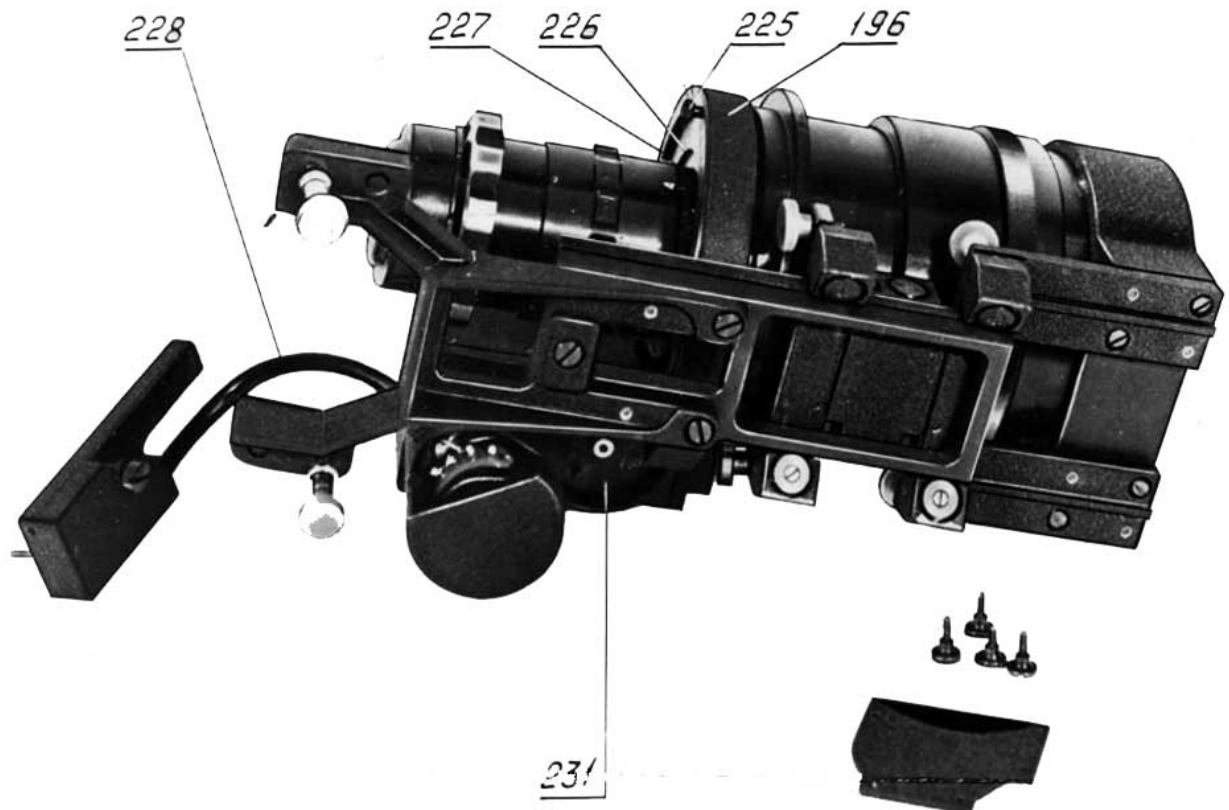

Picture 28. The 300mm lens with the aperture change mechanism and the heavy lens support.

### ***10.6. Mounting the camera onto a tripod.***

The camera can be mounted onto any tripod or support with 3/8" securing screw.

If a tripod has wide base plate, the camera can be set onto a rising adapter plate that allows the camera body door to be opened fully.

The shoulder support has a 3/8" screw too. The position of the camera mounted onto the shoulder support can be adjusted for convenience of an operator by means of the plate screws (214) (Picture 26), bottom support (213), and arms (215, 216).

### ***10.7. Preparation of the 35OPF15-1 lens for anamorphic shots.***

To convert the 35OPF15-1 lens into 35OPF15-1A version, do following:

- 1) insert a rear anamorphic attachment into the rear of the lens and secure it with a fitting ring;
- 2) insert an adapter bushing into the bayonet lock of the lens, so it will be 35OPF15-1A now;
- 3) install a spacer into the aperture change mechanism and secure it with screws;

- 4) mount the aperture change mechanism onto the lens as described in the paragraph 10.4, but value of the shooting speed knob should be set in accordance with the anamorphic diaphragm scale of the lens.

### ***10.8. Mounting of the heating unit.***

Mount an adapter plate first, and secure it with a 3/8" screw. Put the heating unit onto the camera so that round flange of the adapter plate is outside of it. It will be used to mount the camera onto a tripod.

## **11. CONTROLLING THE CAMERA**

### ***11.1. Start and stop.***

Set the “IINTAHNE” switch (201) (Picture 24) into “BKJI” position.

Remote start and stop (using a control unit) is done with the switch (203) “KAMEPA”.

If you are using a shooting speed knob, start and stop the camera with its button “IYCK”.

Note. Change speed from 24 to 150 FPS or back from 150 to 24 FPS smoothly, during 2-3 seconds.

### ***11.2. Setting shooting speed.***

To set a sync 24FPS speed, set the “KADP/C” switch (202) (Picture 24) on the control unit into “24” position.

To set a variable speed, set the “KADP/C” switch (202) into “24-150” position, set the switch (203) into “KAMEPA” position, set desired speed with the knob (24) (Picture 13), and press the “IYCK” on the camera.

## 12. TROUBLESHOOTING

It is strictly forbidden to do following:

- 1) to change factory made schematics and electronics;
- 2) to replace broken parts with other ones having different specifications;
- 3) to use acid instead of colophony for soldering.

If you find a malfunction that can't be fixed without skilled techs, the camera should be sent to a certified workshop. Such malfunctions include:

- a) wear of one of the camera gears;
- b) mechanical damages of the film gate surfaces;
- c) damage of the intermittent movement mechanism.

List of the malfunctions that can be easily fixed is given in the Table 8.

Table 8

<b>Malfunction</b>	<b>Possible cause</b>	<b>How to fix</b>
1. "Salad"	Too short top or bottom film loop	Set the loops correctly
2. Weak winding of the film in a mag	Wrong adjustment of the friction	Adjust the film tension friction in the mag with an adjustment nut
3. Scratches on the film	a) "Scale" on the working surfaces of the film gate	Remove the scale with a soft flannel cloth moisture in 40-60% spirit solution
	b) rollers of the film movement mechanism don't turn	Remove the rollers, wash them in solvent, lubricate them with VNII NP-6 oil and install them back into the camera
4. Tearing of the film when the camera stops	Wrong adjustment of the magnetic brake	Adjust brake with the movable magnet

## **13. EFFORTS AND PERIODICITY OF MAINTENANCE INSPECTIONS**

It is necessary to do regular maintenance procedures (inspecting, cleaning, lubricating, and adjusting if necessary) in order to provide reliable functioning of the camera.

### ***13.1. Cleaning of the camera and mags.***

Clean external surfaces of the camera with soft cloth before and after each use.

Remove dust from interior of the camera by means of rubber syringe. If there are oil drops, clean them with soft cloth.

After passing of each 300m of film, check condition of the film gate surface to prevent deposition of scale.

The scale can be removed with soft flannel cloth moisture in 40-60% spirit solution (GOST 5962-67).

It is forbidden to remove the scale with any sort of hard tools (including wooden and bone ones).

### ***13.2. Cleaning of optics.***

Optical surfaces of lenses and viewfinders should be cleaned very carefully to avoid damage of the coating layer.

Dust particles can be removed with a soft brush or with air blow from a rubber syringe.

Greasy types of dirt (like oil, fingerprints etc.) should be cleaned with a wad of cotton wool moistened in spirit solution. Do not press onto the glass.

Use of chamois leather is forbidden.

### ***13.3. Cleaning of the mirror shutter.***

Don't touch surface of the mirror shutter! Any dust should be removed with air blow from a rubber syringe.

In an exceptional case (like an oil drop or fingerprints) it is permissible to remove such dirt with soft dry cotton wool.

Also, it is alright to use a cotton wool moistened in ether, but don't rub the same place continuously, and don't press the wad of cotton wool.

### ***13.4. Lubricating.***

The camera should be lubricated at least once every three months.

Film channel should be cleaned after passing of each 300mm of film.

In case of long idle time or after passing of 360m of film the camera should be cleaned and lubricated.

Remove old grease from all gears with a suitable solvent. Lubricate them with grease OKB 122-7 (GOST 18179-72). Friction places should be lubed with oil VNII NP-6 (TU38-001168-74).

After lubricating, run the camera for 10-15 seconds. Extra oil should be removed with clean soft cloth.

## **14. DISASSEMBLING AND ASSEMBLING OF THE CAMERA**

After passing of 4320m of film (36 of 120m mags) the camera should be disassembled for cleaning.

Order of disassembling is following:

1. Remove the lens and lens support.
2. Remove the viewfinder and put a protective cap in its place.
3. Remove the mag and install a protective cover in place of it.
4. Turn the body door handle and open the door.
5. Unscrew the two screws and columns, and remove the intermittent movement mechanism.
6. Turn locks and remove the film gate.
7. Unscrew screws on the motor to remove it from the camera.
8. Unscrew screws on the rear side of the camera to remove it.

After inspection, cleaning and lubricating is done, assemble the camera in reverse order.

## **15. CONSERVATION**

To protect open metal parts of the camera from oxidation (corrosion) during transportation and long idle time, it is necessary to conserve the camera.

All metal parts without paint coating (except of the film gate) should be oiled with spindle oil AU (GOST 1642-75).

Don't remove the film gate from the camera during storage.

All metal parts of the mags without paint coating should be oiled too.

This procedure will preserve the camera for six months.